

Easy Series
EasyPact™
MVS

Catalog 2020

LV air circuit breakers
from 630 to 4000A





Green Premium™

An industry leading portfolio of offers delivering sustainable value



More than 75% of our product sales offer superior transparency on the material content, regulatory information and environmental impact of our products:

- RoHS compliance
- REACH substance information
- Industry leading # of PEP's*
- Circularity instructions

The Green Premium program stands for our commitment to deliver customer valued sustainable performance. It has been upgraded with recognized environmental claims and extended to cover all offers including Products, Services and Solutions.

CO₂ and P&L impact through... Resource Performance

Green Premium brings improved resource efficiency throughout an asset's lifecycle. This includes efficient use of energy and natural resources, along with the minimization of CO₂ emissions.

Cost of ownership optimization through... Circular Performance

We're helping our customers optimize the total cost of ownership of their assets. To do this, we provide IoT-enabled solutions, as well as upgrade, repair, retrofit, and remanufacture services.

Peace of mind through... Well-being Performance

Green Premium products are RoHS and REACH compliant. We're going beyond regulatory compliance with step-by-step substitution of certain materials and substances from our products.

Improved sales through... Differentiation

Green Premium delivers strong value propositions through third-party labels and services. By collaborating with third-party organizations we can support our customers in meeting their sustainability goals such as green building certifications.



Discover what we mean by green
Check your products!

*PEP: Product Environmental Profile (i.e. Environmental Product Declaration)

EasyPact MVS range

The easy choice for reliable performance

One family and two frame sizes

- > Performance without compromise
- > Assured quality and safety you can trust
- > Deliver exceptional reliability and flexibility in its class
- > Outstanding value for an optimized feature set
- > Precision engineered to meet your needs
- > Unbeatable value throughout its lifecycle
- > Simple to choose and easy to install

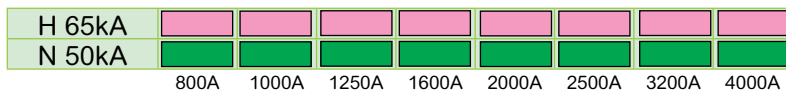

2 sizes:



MVS Frame 1: 630 to 1600A



MVS Frame 2: 800 to 4000A

Choose the leader



- > 630 to 4000A ratings
- > Breaking capacity: 50 & 65kA
- > Suitable for 690V applications
- > Complete selectivity with $I_{cs}=I_{cu}$
- > Intelligent ET range of trip system with display
- > Fully protected neutral on 4 pole breakers
- > Full accessories with modular design
- > Conforms to IEC 60947- 2 & 3

Performance Level

- Ratings:
 - Frame 1: 630 to 1600A
 - Frame 2: 800 to 4000A.
- Breaking capacity: 50 & 65kA
- Suitable for 690V applications
- Complete selectivity with $I_{cs}=100\%I_{cu}$
- Circuit breakers type C,N,H
- Switch-disconnectors type CA,NA,HA
- 3 or 4 poles.
- Fixed or drawout versions.
- Conforms to IEC 60947- 2 & 3

ET range of trip system

Type of measurement

- ET for basic protection
- ETA for "current"
- ETV for "Energy"

Type of protection

- 2.0 for basic protection
- 5.0 for selective protection
- 6.0 for selective + earth-fault protection



Communication

Eco COM

- EasyPact in a communication network.
- BCM-ULP COM option inside breaker
- IFM: Modbus interface module.
- I/O application module.

Transmission signal

- Breaker signal: OF, SDE, PF and CH.
- Cradel signal: CD, CT, CE
- Measurements ways: Instantaneous, maximum/minimum, demand
- Measurements value: current, voltage, power, power factor, energy
- Protection settings
- Trip causes



EasyCom Communication

- Independent Modbus interface module
- Digital Input: 3 sets of OF, SDE, PF
- Digital output: 3 sets of MX & XF
- Analog Input: 1 set of 4-20mA



M2C programmable contacts

- Two programmable contacts
- Signal events: Ir, Isd, Alarm Ir, Alarm Ig, Igv

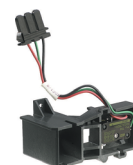

EasyPact MVS Benefits for every customer

EasyPact MVS06 to MVS40

★ Panel builders/ contractors

- > Suitable for copper & Aluminium termination with the pole pitch of 70 or 115 mm
- > Terminal orientation can be converted from horizontal to vertical and vice-versa at workshop
- > Direct mounting Door frames (escutcheon) without drilling any holes
- > Front fitted accessories like under-volt release, shunt release & closing coil for complete range
- > Conversion of manual operated breaker in to electrical operated, with single bolt fixing

EasyPact MVS with modular design helps to increase the shop floor efficiency, enabling faster delivery of switch boards.

★ End Users

- > Moulded case design ensures high endurance without maintenance
- > Intelligent ET range of trip system with thermal memory.
- > Overload run alarm & individual LED indications enable fault identification
- > Icu=Ics=50kA & 65kA ensures complete selectivity
- > Inbuilt safety shutter & interlocks
- > Designed to provide utmost user safety during installation, during use, and while under maintenance.
- > All 4 pole breakers are with fully rated neutral and protected with adjustable settings at OFF – 50%-100%

EasyPact MVS answers even to the most stringent application with most reliable distribution systems assuring continuity of service

★ Designers

- > Conforms to IEC60947-2 for breakers & IEC60947-3 for disconnectors
- > Designed and manufactured using advanced manufacturing methods to match your quality expectations and the needs of each project.
- > Continuous rated coils helps in simple interlocking schemes
- > Extensive choice of software tools & documentation to reduce design time.
- > EasyPact MVS respects the environment throughout their life cycle

EasyPact MVS is designed to meet the needs of your customers with flexibility to achieve system efficiency during the design phase



The Key values

90%
of applications are covered



The performance you need

EasyPact MVS provides the ideal level of capability for your installation from 630 to 4000 A.

Reduce stock by up to
30%



At a cost-effective investment

Pay for what you need: Get outstanding durability with the features you need, with the benefit of easy to order and stock.

100%
Commitment to quality



With the quality you demand

Designed and manufactured by Schneider Electric using advanced manufacturing methods and premium materials.

Gain peace of
mind and
optimised cost
for every
installation





Exceptional
reliability, flexibility
and convenience

+



Quality and safety
you can trust

=

Performance
without compromise

Outstanding value for
an optimized feature set



Buildings



Industry



Panelbuilders

General contents

EasyPact™ MVS

Functions and characteristics	A-1
----------------------------------	-----

Installation recommendations	B-1
---------------------------------	-----

Dimensions and connection	C-1
------------------------------	-----

Electrical diagrams	D-1
---------------------	-----

Additional characteristics	E-1
-------------------------------	-----

Catalogue numbers and order form	F-1
-------------------------------------	-----

Functions and characteristics



General overview	A-2
Detailed contents	A-2
Circuit breakers and switch-disconnectors	A-4
MVS06 to MVS16(Frame 1)	A-4
Circuit breakers and switch-disconnectors	A-6
MVS08 to MVS40(Frame 2)	A-6
Identifying ET range of trip system	A-8
Overview of functions	A-10
ET trip system	A-10
ETA trip system	A-12
ETV trip system	A-14
ET range of trip system	A-16
Accessories and test equipment	A-16
Eco Com Communication	A-17
IFM Modbus Communication Interface	A-18
EasyCom Communication Interface	A-24
Connections	A-28
Overview of solutions and accessories	A-28
Accessories and auxiliaries	A-30
Locking	A-32
On the device	A-32
On the chassis	A-33
Indication contacts	A-34
Remote operation	A-36
Remote ON / OFF	A-36
Remote tripping	A-38
Source-changeover systems	A-39
Mechanical interlocking	A-39
Electrical interlocking	A-40
IVE unit	A-40
Controller selection	A-41
Accessories	A-42
<i>Installation recommendations</i>	<i>B-1</i>
<i>Dimensions and connection</i>	<i>C-1</i>
<i>Electrical diagrams</i>	<i>D-1</i>
<i>Additional characteristics</i>	<i>E-1</i>
<i>Catalogue numbers and order form</i>	<i>F-1</i>

This overview describes all the functions offered by EasyPact MVS devices.



ET21 trip system.



ET55 trip system.



ET6G trip system.

Circuit breakers and switch-disconnectors page A-4

- Ratings:
 - EasyPact MVS 630 to 4000 A
 - Circuit breakers type C, N, H
 - Switch-disconnectors type CA, NA, HA
 - 3 or 4 poles
 - Fixed or draw-out versions

ET trip system page A-8

- 2I basic protection
- 5S selective protection
- 6G selective + earth-fault protection
- Standard long-time rating plug:
 - Current setting (A) 0.4 to 1 x I_n

ETA trip system with current measurement page A-10

- 2I basic protection
- 5S selective protection
- 6G selective + earth-fault protection
- Standard long-time rating plug:
 - Current setting (A) 0.4 to 1 x I_n
- External power-supply module

ETV trip system with energy measurement page A-12

- 2I basic protection
- 5S selective protection
- 6G selective + earth-fault protection
- Standard long-time rating plug:
 - Current setting (A) 0.4 to 1 x I_n
- External power-supply module

Connections page A-15

- Rear connection:
 - Horizontal
 - Vertical
- Optional accessories:
 - Interphase barriers
 - Safety shutters and shutter locking blocks



Safety shutters



Interphase barriers

Locking page A-18

- Pushbutton locking by padlockable transparent cover
- OFF-position locking by keylock
- Chassis locking in disconnected position by keylock
- Chassis locking in connected, disconnected and test positions
- Door interlock (inhibits door opening with breaker in 'connected' or 'test' position)

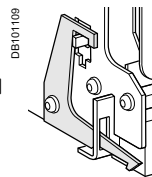

Door interlock

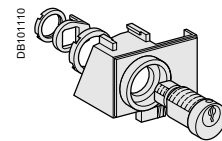

Chassis key lock

PB104354A40

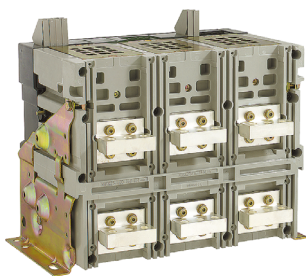

CPB100003

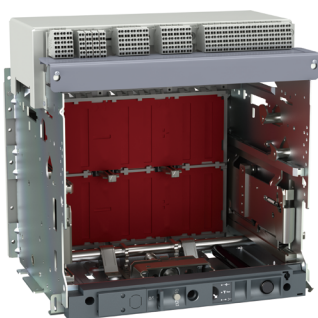

CPB100015

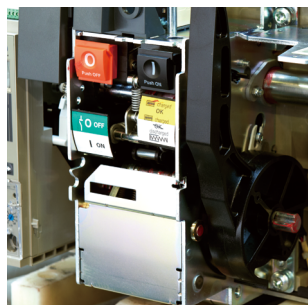

CPB100016



Indication contacts

page A-20

- Standard:
 - ON/OFF indication (OF)
 - "Fault" trip indication (SDE)
- Optional:
 - Additional ON/OFF indication (OF)
 - Ready-to-close contact (PF)
 - Carriage switches for connected (CE) disconnected (CD) and test (CT) positions

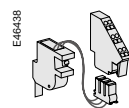

Ready-to-close contact

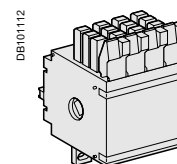

OF contact

Remote operation

page A-21

- Remote ON/OFF:
 - Gear motor
 - XF closing or MX opening voltage releases
- Remote tripping function:
 - MN voltage release
 - Standard
 - Adjustable or non-adjustable delay

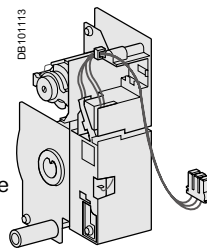

Gear motor

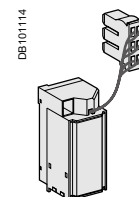

MX, XF and MN voltage releases

Accessories

page A-25

- Auxiliary terminal shield
- Operation counter
- Escutcheon (Door sealing frame)
- Transparent cover for escutcheon
- Escutcheon blanking plate

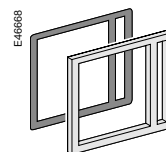

Escutcheon

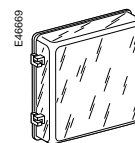

Transparent cover

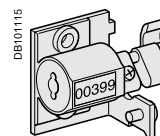

Mechanical operation counter

Source-changeover systems

page A-24

- Mechanical interlocking using cables:
 - Interlocking between two devices
 - Interlocking between three devices

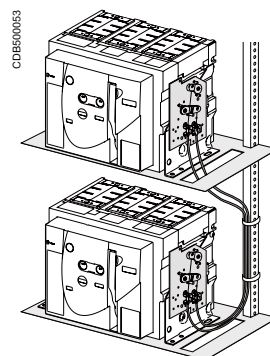

Interlocking of two devices

Circuit breakers and switch-disconnectors

MVS06 to MVS16(Frame 1)

CPB100000



Circuit breaker.

Common characteristics

Number of poles		3/4
Rated insulation voltage (V)	Ui	1000
Impulse withstand voltage (kV)	Uimp	12
Rated operational voltage (V AC 50/60 Hz)	Ue	440
Suitability for isolation	IEC 60947-2	Yes
Degree of pollution	IEC 60664-1	3

Basic circuit-breaker

Circuit-breaker as per IEC 60947-2

Rated current (A)	In	at 40°C ⁽¹⁾
-------------------	----	------------------------

Rating of 4th pole (A)

Sensor ratings (A)

Type of circuit breaker

Ultimate breaking capacity (kA rms)	Icu	220...440V
Rated service breaking capacity (kA rms)	Ics	% Icu
Utilisation category		
Rated short-time withstand current (kA rms) V AC 50/60 Hz	Icw	1s 220...440 V
		3s 440V
Rated making capacity (kA peak)	Icm	220...440 V
Integrated instantaneous protection(DIN KA instantaneous ±10%)		
Breaking time (ms) between tripping order and arc extinction(ms)		
Closing time (ms)		

Switch-disconnector as per IEC60947-3 and Annex A

Type of switch-disconnector

Operational current AC23A

Rated making capacity (kA peak)	Icm	
Rated short-time withstand current (kA rms)	Icw	1s
		3s

Maintenance/Connection/Installation

Service life	Mechanical	with maintenance	
		without maintenance	
C/O cyclesx1000	Electrical	without maintenance	440 V
		Vertical	
Connection	Horizontal		
	Vertical		
Dimensions (mm) (H x W x D)	Draw-out		3P
			4P
	Fixed		3P
			4P
Weight (kg) (approximate)	Draw-out		3P/4P
	Fixed		3P/4P

⁽¹⁾ Refer page no. B-12 for details on temperature derating.

	MVS06	MVS08	MVS10	MVS12	MVS16
	630	800	1000	1250	1600
	630	800	1000	1250	1600
	630	800	1000	1250	1600
	C	C	C	C	C
	50	50	50	50	50
	100%	100%	100%	100%	100%
	B	B	B	B	B
	35	35	35	35	35
	20	20	20	20	20
	105	105	105	105	105
	105	105	105	105	105
	25	25	25	25	25
	<50	<50	<50	<50	<50
	MVS06	MVS08	MVS10	MVS12	MVS16
	CA	CA	CA	CA	CA
	630	800	1000	1250	1600
	75	75	75	75	75
	35	35	35	35	35
	20	20	20	20	20
	20	20	20	20	20
	10	10	10	10	10
	5	5	5	5	5
	Yes				
	Yes				
	322x288x277				
	322x358x277				
	301x276x196				
	301x346x196				
	30/39				
	14/18				

Circuit breakers and switch-disconnectors

MVS08 to MVS40(Frame 2)



Circuit breaker.



Switch disconnector.

Common characteristics

Number of poles		3/4
Rated insulation voltage (V)	Ui	1000
Impulse withstand voltage (kV)	Uimp	12
Rated operational voltage (V AC 50/60 Hz)	Ue	690
Suitability for isolation	IEC 60947-2	Yes
Degree of pollution	IEC 60664-1	4

Basic circuit-breaker

Circuit-breaker as per IEC 60947-2

Rated current (A)	In	at 40°C ⁽¹⁾
Rating of 4th pole (A)		

Sensor ratings (A)

Type of circuit breaker

Ultimate breaking capacity (kA rms) V AC 50/60 Hz	Icu	220...440V 690 V
Rated service breaking capacity (kA rms)	Ics	% Icu
Utilisation category		
Rated short-time withstand current (kA rms) V AC 50/60 Hz	Icw	1s 220...440 V 690V 3s 440/690V
Rated making capacity (kA peak) V AC 50/60 Hz	Icm	220...440 V 690 V

Breaking time (ms) between tripping order and arc extinction

Closing time (ms)

Switch-disconnector as per IEC60947-3 and Annex A

Type of switch-disconnector

Operational current AC23A		
Rated making capacity (kA peak)	Icm	
Rated short-time withstand current (kA rms)	Icw	1s 3s

Maintenance/Connection/Installation

Service life C/O cyclesx1000	Mechanical	with maintenance	
		without maintenance	
	Electrical	without maintenance	440 V 690 V
Connection		Horizontal Vertical	
Dimensions (mm) (H x W x D)		Draw-out	3P 4P
		Fixed	3P 4P
Weight (kg) (approximate)		Draw-out	3P/4P
		Fixed	3P/4P

⁽¹⁾ Refer page no. B-12 for details on temperature derating.

MVS08		MVS10		MVS12		MVS16		MVS20		MVS25		MVS32		MVS40	
800		1000		1250		1600		2000		2500		3200		4000	
800		1000		1250		1600		2000		2500		3200		4000	
800		1000		1250		1600		2000		2500		3200		4000	
N	H	N	H	N	H	N	H	N	H	N	H	N	H	N	H
50	65	50	65	50	65	50	65	50	65	50	65	50	65	55	65
42	50	42	50	42	50	42	50	42	50	42	50	42	50	42	50
100%		100%		100%		100%		100%		100%		100%		100%	
B		B		B		B		B		B		B		B	
50	65	50	65	50	65	50	65	50	65	50	65	50	65	55	65
42	50	42	50	42	50	42	50	42	50	42	50	42	50	42	50
25	36	25	36	25	36	25	36	25	36	25	36	25	36	30	36
105	143	105	143	105	143	105	143	105	143	105	143	105	143	121	143
88	105	88	105	88	105	88	105	88	105	88	105	88	105	88	105
25		25		25		25		25		25		25		25	
<70		<70		<70		<70		<70		<70		<70		<70	
MVS08		MVS10		MVS12		MVS16		MVS20		MVS25		MVS32		MVS40	
NA	HA	NA	HA	NA	HA	NA	HA	NA	HA	NA	HA	NA	HA	NA	HA
800		1000		1250		1600		2000		2500		3200		4000	
105	143	105	143	105	143	105	143	105	143	105	143	105	143	121	143
50	65	50	65	50	65	50	65	50	65	50	65	50	65	55	65
25	36	25	36	25	36	25	36	25	36	25	36	25	36	30	36
20		20		20		20		20		20		20		20	
10		10		10		10		10		10		10		10	
6000		6000		6000		6000		6000		5000		5000		5000	
4000		4000		4000		4000		4000		2500		2500		2500	
Yes		Yes		Yes		Yes		Yes		Yes		Yes		Yes	
439 x 441 x 395		439 x 556 x 395		352 x 422 x 297		352 x 537 x 297		70/85		90/120		40/50		60/80	
70/85		90/120		40/50		60/80									
40/50		60/80													

Identifying ET range of trip system

EasyPact MVS circuit breakers equipped with ET range of trip system are designed to protect power circuit and connected loads. Measurement of current and Energy helps users to maintain continuity of service and optimize installation.



Dependability

Integration of protection functions in an ASIC electronic component used in all trip units guarantees a high degree of reliability and immunity to conducted or radiated disturbances.

On ET range, measurement functions are managed by an independent microprocessor. Protection functions are independent of measurement functions, ensure system protection even at very low load currents.

Accessories

Certain functions require the addition of trip unit accessories, described on page A-14.

Trip unit name codes

Type of protection

- 2I for basic protection
- 5S for selective protection
- 6G for selective + earth-fault protection

Type of measurement

- ET for basic
- ETA for "Current"
- ETV for "Current" and "Energy"

ET2I: basic protection

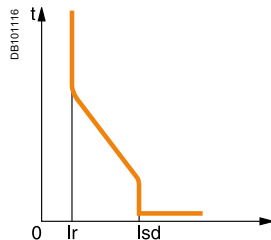

Protection:
long time
+ instantaneous

ET5S: selective protection

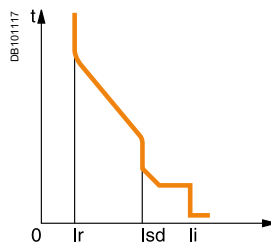

Protection:
long time
+ short time
+ instantaneous

ET6G: selective + earth-fault protection

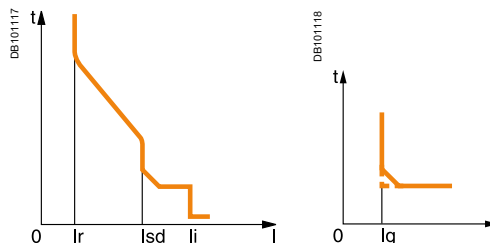







Protection:
long time
+ short time
+ instantaneous
+ earth fault





Protection and measurement functions

ET	ETA	ETV
<ul style="list-style-type: none">■ Fault indications■ Settings in amperes and in seconds	<ul style="list-style-type: none">■ $I_1, I_2, I_3, I_N, I_{\text{earth-fault}}$, and maximeter for these measurements:<ul style="list-style-type: none">□ Fault indications□ Settings in amperes and in seconds	<ul style="list-style-type: none">■ Incorporates all the rms measurements of ETA trip unit, plus voltage, power factor, power and energy metering measurements:<ul style="list-style-type: none">□ Calculates the current demand value□ “Quickview” function for the automatic cyclical display of the most useful values

2I CDB500000 	2I CDB500028 	2I CDB500035 
--	--	--

5S CDB500001 	5S CDB500029 	5S CDB500030 
---	---	---

6G CDB500002 	6G CDB500003 	6G CDB500004 
---	---	---

ET trip unit protect power circuits, under overload & short-circuit conditions. They are equipped with individual fault trip indication LEDs. ET6G provides earth-fault protection.

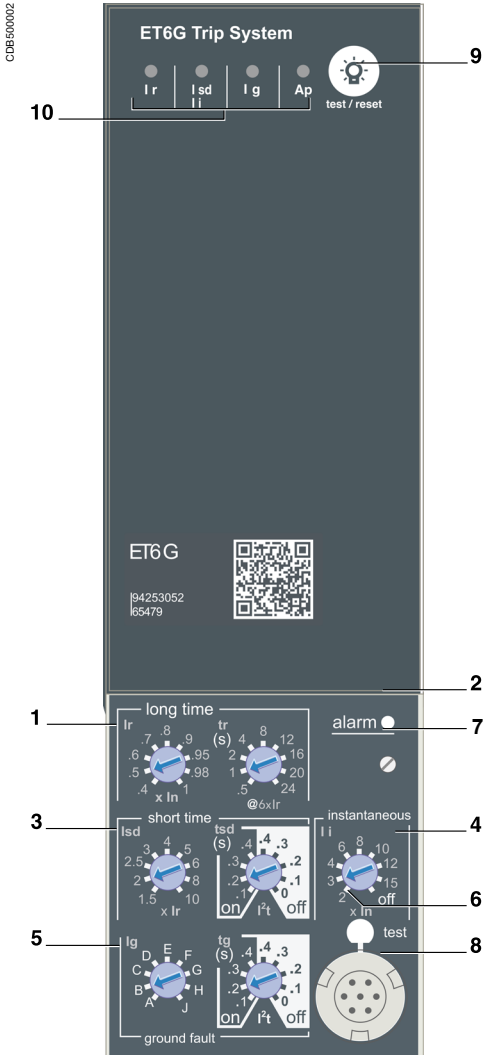

- 1 Long-time threshold and tripping delay.
- 2 Overload alarm (LED) at 1, 125 Ir.
- 3 Short-time pick-up and tripping delay.
- 4 Instantaneous pick-up.
- 5 Earth-fault pick-up and tripping delay.
- 6 Earth-fault test button.
- 7 Long-time rating plug screw.
- 8 Test connector.
- 9 Lamp test, reset and battery test.
- 10 Indication of tripping cause.

(1) The thermal memory continuously accounts for the amount of heat in the cables, both before and after tripping, whatever the value of the current (presence of an overload or not). The thermal memory optimises the long-time protection function of the circuit breaker by taking into account the temperature rise in the cables. The thermal memory assumes a cable cooling time of approximately 20 minutes.

(2) Refer to page D-5 for more details on ZSI.

Note: ET trip control units come with a transparent leadseal cover as standard.

Protection

Protection thresholds and delays are set using the adjustment dials.

Overload protection

True rms long-time protection.
Protects cables (phase and neutral) against overloads
Thermal memory⁽¹⁾: thermal image before and after tripping.

Short-time protection

- The short-time protection function protects the distribution system against impedant short-circuits
- The short-time tripping delay can be used to ensure discrimination with downstream circuit breaker
- The I²t ON and I²t OFF options enhance discrimination with a downstream protection devices
- Use of I²t curves with short-time protection:
 - I²t OFF selected: the protection function implements a constant time curve
 - I²t ON selected: the protection function implements an I²t inverse-time curve up to 10 Ir. Above 10 Ir, the time curve is constant

Earth-fault protection on ET6G trip system

Residual earth fault protection.
Selection of I²t type (ON or OFF) for delay.
A ground fault in the protection conductors can provoke local temperature rise at the site of the fault or in the conductors. The purpose of the ground-fault protection function is to eliminate this type of fault.

Type	Description
Residual	<ul style="list-style-type: none"> ■ The function determines the zero-phase sequence current, i.e. the vectorial sum of the phase and neutral currents ■ It detects faults downstream of the circuit breaker

Instantaneous protection

The Instantaneous-protection function protects the distribution system against solid short-circuits. Contrary to the short-time protection function, the tripping delay for instantaneous protection is not adjustable. The tripping order is sent to the circuit breaker as soon as current exceeds the set value, with a fixed time delay of 20 milliseconds.

Neutral protection

On three-pole circuit breakers, neutral protection is not possible.
On four-pole circuit breakers, neutral protection may be set using a three-position switch: neutral unprotected (4P 3d), neutral protection at 0.5 Ir (4P 3d + N/2), neutral protection at Ir (4P 4d).

Zone selective interlocking (ZSI)

A ZSI⁽²⁾ terminal block may be used to interconnect a number of control units to provide total discrimination for short-time and earth-fault protection, without a delay before tripping.

Overload alarm

A yellow alarm LED goes on when the current exceeds the long-time trip threshold.

Fault indications

- LEDs indicate the type of fault:
- Overload (long-time protection Ir)
 - Short-circuit (short-time Isd or instantaneous Ii protection)
 - Earth fault (I_g)
 - Internal fault (Ap)

Battery power

The fault indicating LEDs are powered by an in-built battery. The fault indication LEDs remain on until the test/reset button is pressed.

Test

A hand-held test kit may be connected to the test connector on the front to check circuit-breaker operation. For ET6G trip unit, the operation of earth-fault protection can be checked by pressing the test button located above the test connector.



Protection		ET2I									
Long time		ET2I									
Current setting (A)	$I_r = I_n \times \dots$	0.4	0.5	0.6	0.7	0.8	0.9	0.95	0.98	1	
Tripping between 1.05 and 1.20 x I_r											
Time setting	tr (s)	0.5	1	2	4	8	12	16	20	24	
Time delay (s)	Accuracy: 0 to -30 %	$1.5 \times I_r$	12.5	25	50	100	200	300	400	500	600
	Accuracy: 0 to -20 %	$6 \times I_r$	0.7 ⁽¹⁾	1	2	4	8	12	16	20	24
	Accuracy: 0 to -20 %	$7.2 \times I_r$	0.7 ⁽²⁾	0.69	1.38	2.7	5.5	8.3	11	13.8	16.6
Thermal memory		20 minutes before and after tripping									
(1) 0 to -40 % - (2) 0 to -60 %											
Instantaneous											
Pick-up (A)	$I_{sd} = I_r \times \dots$	1.5	2	2.5	3	4	5	6	8	10	
Accuracy: $\pm 10\%$											
Time delay		Max resettable time: 20 ms Max break time: 80 ms									

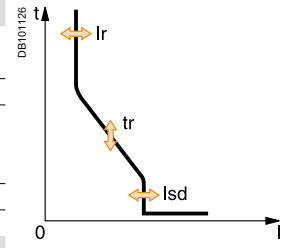

Protection		ET5S/ET6G										
Long time		ET5S/ET6G										
Current setting (A)	$I_r = I_n \times \dots$	0.4	0.5	0.6	0.7	0.8	0.9	0.95	0.98	1		
Tripping between 1.05 and 1.20 x I_r												
Time setting	tr (s)	0.5	1	2	4	8	12	16	20	24		
Time delay (s)	Accuracy: 0 to -30 %	$1.5 \times I_r$	12.5	25	50	100	200	300	400	500	600	
	Accuracy: 0 to -20 %	$6 \times I_r$	0.7 ⁽¹⁾	1	2	4	8	12	16	20	24	
	Accuracy: 0 to -20 %	$7.2 \times I_r$	0.7 ⁽²⁾	0.69	1.38	2.7	5.5	8.3	11	13.8	16.6	
Thermal memory		20 minutes before and after tripping										
(1) 0 to -40 % - (2) 0 to -60 %												
Short time												
Pick-up (A)	$I_{sd} = I_r \times \dots$	1.5	2	2.5	3	4	5	6	8	10		
Accuracy: $\pm 10\%$												
Time setting tsd (s)	Settings	I^2t Off	0	0.1	0.2	0.3	0.4					
		I^2t On	-	0.1	0.2	0.3	0.4					
Time delay (ms) at 10 x I_r (I^2t Off or I^2t On)	tsd (max resettable time)		20	80	140	230	350					
		tsd (max break time)	80	140	200	320	500					
Instantaneous												
Pick-up (A)	$I_i = I_n \times \dots$	2	3	4	6	8	10	12	15	off		
Accuracy: $\pm 10\%$												
Time delay		Max resettable time: 20 ms Max break time: 50 ms										
Earth fault		ET6G										
Pick-up (A)	$I_g = I_n \times \dots$	A	B	C	D	E	F	G	H	J		
Accuracy: $\pm 10\%$	$I_n \leq 400$ A	0.3	0.3	0.4	0.5	0.6	0.7	0.8	0.9	1		
	400 A < $I_n \leq 1000$ A	0.2	0.3	0.4	0.5	0.6	0.7	0.8	0.9	1		
	$I_n \geq 1250$ A	500	640	720	800	880	960	1040	1120	1200		
Time setting tg (s)	Settings	I^2t Off	0	0.1	0.2	0.3	0.4					
		I^2t On	-	0.1	0.2	0.3	0.4					
Time delay (ms)	tg (max resettable time)		20	80	140	230	350					
		tg (max break time)	80	140	200	320	500					

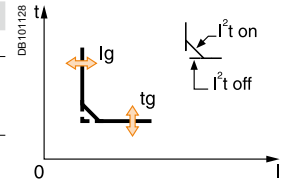
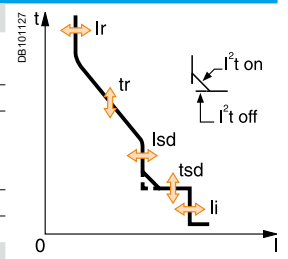

Note: All current-based protection functions require no auxiliary source.
The test / reset button, clears the tripping indication and tests the battery.

ETA trip units include all functions offered by ET trip unit. In addition, they also offer measurements, display and current maximeters.

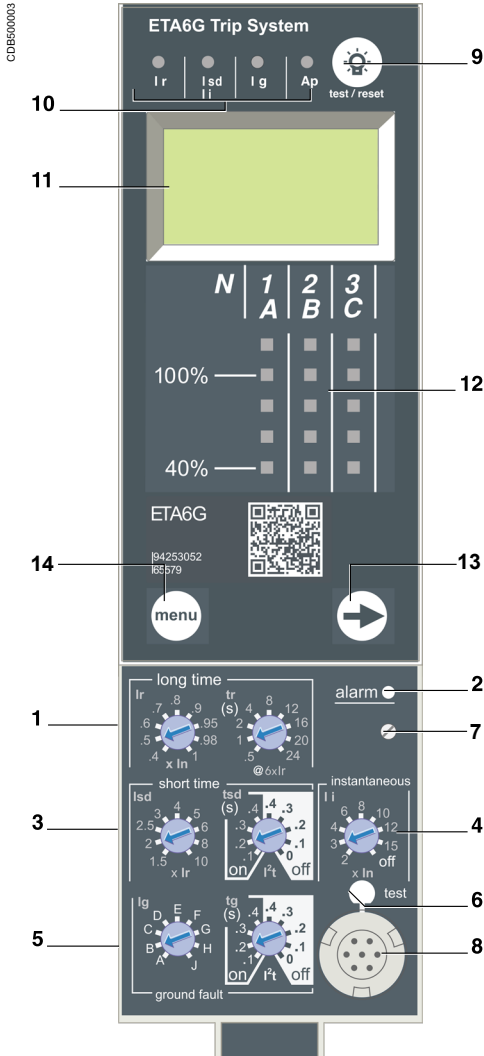

- 1 Long-time threshold and tripping delay.
- 2 Overload alarm (LED) at 1,125 Ir.
- 3 Short-time pick-up and tripping delay.
- 4 Instantaneous pick-up.
- 5 Earth-fault pick-up and tripping delay.
- 6 Earth-fault test button.
- 7 Long-time rating plug screw.
- 8 Test connector.
- 9 Lamp test, reset and battery test.
- 10 Indication of tripping cause.
- 11 Digital display.
- 12 Three-phase bargraph and ammeter.
- 13 Navigation button to view menu contents.
- 14 Navigation button to change menu.

(1) The thermal memory continuously accounts for the amount of heat in the cables, both before and after tripping, whatever the value of the current (presence of an overload or not). The thermal memory optimises the long-time protection function of the circuit breaker by taking into account the temperature rise in the cables. The thermal memory assumes a cable cooling time of approximately 20 minutes.

(2) Refer to page D-5 for more details on ZSI.

Note: ETA trip units come with a transparent leadseal cover as standard.

“Ammeter” measurements

ETA trip units measure the true (rms) value of currents.

They provide continuous current measurements from 0.2 to 1.2 In and are accurate to within 1.5 % (including the sensors).

A digital LCD screen continuously displays the most heavily loaded phase (Imax) or displays the I₁, I₂, I₃, I_N, I_g, stored-current (maximeter) and setting values by successively pressing the navigation button.

The optional external power supply makes it possible to display currents < 20 % In. Below 0.1 In, measurements are not significant. Between 0.1 and 0.2 In, accuracy changes linearly from 4 % to 1.5 %.

Protection

Protection thresholds and delays are set using the adjustment dials.

Overload protection

True rms long-time protection.

Protects cables (phase and neutral) against overloads

Thermal memory⁽¹⁾: thermal image before and after tripping.

Short-time protection

- The short-time protection function protects the distribution system against impedant short-circuits

- The short-time tripping delay can be used to ensure discrimination with downstream circuit breaker

- The I²t ON and I²t OFF options enhance discrimination with a downstream protection devices

- Use of I²t curves with short-time protection:

- I²t OFF selected: the protection function implements a constant time curve

- I²t ON selected: the protection function implements an I²t inverse-time curve up to 10 Ir. Above 10 Ir, the time curve is constant

Earth-fault protection on ETA6G trip system

Residual earth fault protection.

Selection of I²t type (ON or OFF) for delay.

A ground fault in the protection conductors can provoke local temperature rise at the site of the fault or in the conductors. The purpose of the ground-fault protection function is to eliminate this type of fault.

Type	Description
Residual	<ul style="list-style-type: none"> ■ The function determines the zero-phase sequence current, i.e. the vectorial sum of the phase and neutral currents ■ It detects faults downstream of the circuit breaker

Instantaneous protection

The Instantaneous-protection function protects the distribution system against solid short-circuits. Contrary to the short-time protection function, the tripping delay for instantaneous protection is not adjustable. The tripping order is sent to the circuit breaker as soon as current exceeds the set value, with a fixed time delay of 20 milliseconds.

Neutral protection

On three-pole circuit breakers, neutral protection is not possible.

On four-pole circuit breakers, neutral protection may be set using a three-position switch: neutral unprotected (4P 3d), neutral protection at 0.5 Ir (4P 3d + N/2), neutral protection at Ir (4P 4d).

Zone selective interlocking (ZSI)

A ZSI⁽²⁾ terminal block may be used to interconnect a number of control units to provide total discrimination for short-time and earth-fault protection, without a delay before tripping.

Overload alarm

A yellow alarm LED goes on when the current exceeds the long-time trip threshold.

Fault indications

LEDs indicate the type of fault:

- Overload (long-time protection Ir)

- Short-circuit (short-time Isd or instantaneous Ii protection)

- Earth fault (I_g)

- Internal fault (Ap)

Battery power

The fault indicating LEDs are powered by an in-built battery. The fault indication LEDs remain on until the test/reset button is pressed.

Test

A hand-held test kit may be connected to the test connector on the front to check circuit-breaker operation. For ETA6G trip unit, the operation of earth-fault protection can be checked by pressing the test button located above the test connector.



Protection		ETA2I									
Long time		ETA2I									
Current setting (A)	$I_r = I_n \times \dots$	0.4	0.5	0.6	0.7	0.8	0.9	0.95	0.98	1	
Tripping between 1.05 and 1.20 x I_r											
Time setting		tr (s)	0.5	1	2	4	8	12	16	20	24
Time delay (s)	Accuracy: 0 to -30 %	$1.5 \times I_r$	12.5	25	50	100	200	300	400	500	600
	Accuracy: 0 to -20 %	$6 \times I_r$	0.7 ⁽¹⁾	1	2	4	8	12	16	20	24
	Accuracy: 0 to -20 %	$7.2 \times I_r$	0.7 ⁽²⁾	0.69	1.38	2.7	5.5	8.3	11	13.8	16.6
Thermal memory		20 minutes before and after tripping									
(1) 0 to -40 % - (2) 0 to -60 %											
Instantaneous											
Pick-up (A)	$I_{sd} = I_r \times \dots$	1.5	2	2.5	3	4	5	6	8	10	
Accuracy: $\pm 10\%$											
Time delay		Max resettable time: 20 ms Max break time: 80 ms									

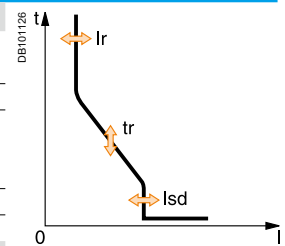

Protection		ETA5S/ETA6G										
Long time		ETA5S/ETA6G										
Current setting (A)	$I_r = I_n \times \dots$	0.4	0.5	0.6	0.7	0.8	0.9	0.95	0.98	1		
Tripping between 1.05 and 1.20 x I_r												
Time setting		tr (s)	0.5	1	2	4	8	12	16	20	24	
Time delay (s)	Accuracy: 0 to -30 %	$1.5 \times I_r$	12.5	25	50	100	200	300	400	500	600	
	Accuracy: 0 to -20 %	$6 \times I_r$	0.7 ⁽¹⁾	1	2	4	8	12	16	20	24	
	Accuracy: 0 to -20 %	$7.2 \times I_r$	0.7 ⁽²⁾	0.69	1.38	2.7	5.5	8.3	11	13.8	16.6	
Thermal memory		20 minutes before and after tripping										
(1) 0 to -40 % - (2) 0 to -60 %												
Short time												
Pick-up (A)	$I_{sd} = I_r \times \dots$	1.5	2	2.5	3	4	5	6	8	10		
Accuracy: $\pm 10\%$												
Time setting tsd (s)	Settings	I^2t Off	0	0.1	0.2	0.3	0.4					
		I^2t On	-	0.1	0.2	0.3	0.4					
Time delay (ms) at 10 x I_r (I^2t Off or I^2t On)	tsd (max resettable time)		20	80	140	230	350					
		tsd (max break time)	80	140	200	320	500					
Instantaneous												
Pick-up (A)	$I_i = I_n \times \dots$	2	3	4	6	8	10	12	15	off		
Accuracy: $\pm 10\%$												
Time delay		Max resettable time: 20 ms Max break time: 50 ms										

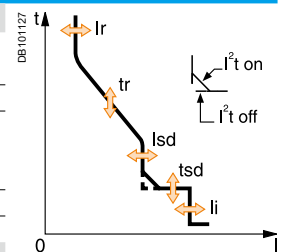

Earth fault		ETA6G										
Pick-up (A)	$I_g = I_n \times \dots$	A	B	C	D	E	F	G	H	J		
Accuracy: $\pm 10\%$	$I_n \leq 400$ A	0.3	0.3	0.4	0.5	0.6	0.7	0.8	0.9	1		
	400 A < $I_n \leq 1000$ A	0.2	0.3	0.4	0.5	0.6	0.7	0.8	0.9	1		
	$I_n \geq 1250$ A	500	640	720	800	880	960	1040	1120	1200		
Time setting tg (s)	Settings	I^2t Off	0	0.1	0.2	0.3	0.4					
		I^2t On	-	0.1	0.2	0.3	0.4					
Time delay (ms)	tg (max resettable time)		20	80	140	230	350					
		tg (max break time)	80	140	200	320	500					

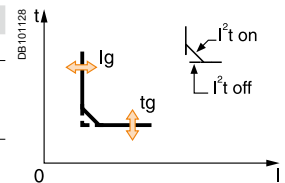

Ammeter		ETA 2I/ETA5S/ETA6G		
Type of measurements		Range	Accuracy	
Instantaneous currents	I_1, I_2, I_3, I_N	$0.2 \times I_n$ to $1.2 \times I_n$	$\pm 1.5\%$	
	I_g (ETA6G)	$0.2 \times I_n$ to I_n	$\pm 10\%$	
Current maximizers of	I_1, I_2, I_3, I_N	$0.2 \times I_n$ to $1.2 \times I_n$	$\pm 1.5\%$	

Note: All current-based protection functions require no auxiliary source.
The test / reset button resets maximizers, clears the tripping indication and tests the battery.

ETV trip units include all the functions offered by ETA. In addition, they measure Energy values. They also offer trip history & display tripping cause.

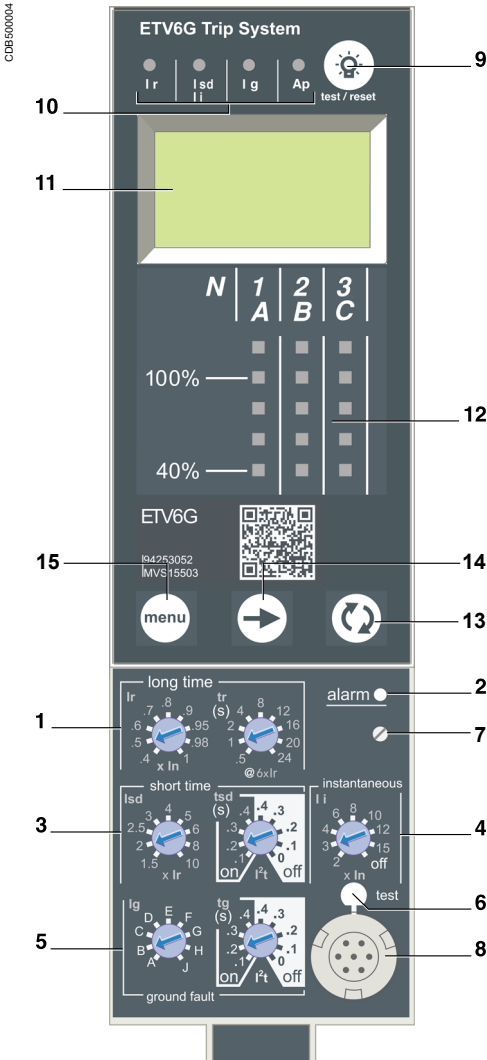

- 1 Long-time threshold and tripping delay.
- 2 Overload alarm (LED) at 1,125 Ir.
- 3 Short-time pick-up and tripping delay.
- 4 Instantaneous pick-up.
- 5 Earth-fault pick-up and tripping delay.
- 6 Earth-fault test button.
- 7 Long-time rating plug screw.
- 8 Test connector.
- 9 Lamp test, reset and battery test.
- 10 Indication of tripping cause.
- 11 Digital display.
- 12 Three-phase bargraph and ammeter.
- 13 Navigation button "quick View" (only with ETV).
- 14 Navigation button to view menu contents.
- 15 Navigation button to change menu.

"Energy meter" measurements

In addition to the ammeter measurements of ETA

ETV control units measure and display:

- current demand
- voltages: phase to phase, phase to neutral, average ⁽¹⁾ and unbalanced ⁽¹⁾
- instantaneous power: P, Q, S
- power factor: PF
- power demand: P demand
- energy: Ep, Eq ⁽¹⁾, Es ⁽¹⁾.

Accuracy of active energy Ep is 2% (including the sensors). The range of measurement is the same as current with ETA, depending of an external power supply module (24 V DC).

Communication option

In conjunction with the COM communication option, the control unit transmits the following:

- settings
- all "ammeter" and "energy" measurements
- tripping causes
- maximeter / minimeter readings.

Protection

Protection thresholds and delays are set using the adjustment dials.

Overload protection

True rms long-time protection. Thermal memory: thermal image before and after tripping. Setting accuracy may be enhanced by limiting the setting range using a different long-time rating plug.

Short-circuit protection

Short-time (rms) and instantaneous protection. Selection of I²t type (ON or OFF) for short-time delay.

Earth-fault protection

Residual or source ground return earth fault protection. Selection of I²t type (ON or OFF) for delay

Neutral protection

On three-pole circuit breakers, neutral protection is not possible. On four-pole circuit breakers, neutral protection may be set using a three-position switch: neutral unprotected (4P 3d), neutral protection at 0.5 Ir (4P 3d + N/2), neutral protection at Ir (4P 4d).

Zone selective interlocking (ZSI)

A ZSI terminal block may be used to interconnect a number of control units to provide total selectivity for short-time and earth-fault protection, without a delay before tripping.

Overload alarm

A yellow alarm LED goes on when the current exceeds the long-time trip threshold.

M2C programmable contacts

The M2C (two contacts) programmable contacts may be used to signal events (Ir, Isd, Alarm Ir, Alarm Ig, Ig). They can be programmed using the keypad on the ETV control unit or remotely using the COM option (BCM ULP).

Fault indications

LEDs indicate the type of fault:

- overload (long-time protection Ir)
- short-circuit (short-time Isd or instantaneous Ii protection)
- earth fault (Ig)
- internal fault (Ap).

Trip history

The trip history displays the list of the last 10 trips. For each trip, the following indications are recorded and displayed:

- the tripping cause: Ir, Isd, Ii, Ig or Auto-protection (Ap) trips
- the date and time of the trip (requires communication option).

Battery power

The fault indication LEDs remain on until the test/reset button is pressed. Under normal operating conditions, the battery supplying the LEDs has a service life of approximately 10 years.

Test

A mini test kit or a portable test kit may be connected to the test connector on the front to check circuit breaker operation. For ETV6G control units, the operation of earth-fault or earth-leakage protection can be checked by pressing the test button located above the test connector.

Note: ETV trip units come with a transparent leadseal cover as standard.



Protection		ETV2I									
Long time		ETV2I									
Current setting (A)	$I_r = I_n \times \dots$	0.4	0.5	0.6	0.7	0.8	0.9	0.95	0.98	1	
Tripping between 1.05 and 1.20 x I_r											
Time setting	tr (s)	0.5	1	2	4	8	12	16	20	24	
Time delay (s)	Accuracy: 0 to -30 %	1.5 x I_r	12.5	25	50	100	200	300	400	500	600
	Accuracy: 0 to -20 %	6 x I_r	0.7 ⁽¹⁾	1	2	4	8	12	16	20	24
	Accuracy: 0 to -20 %	7.2 x I_r	0.7 ⁽²⁾	0.69	1.38	2.7	5.5	8.3	11	13.8	16.6
Thermal memory		20 minutes before and after tripping									
(1) 0 to -40 % - (2) 0 to -60 %											
Instantaneous											
Pick-up (A)	$I_{sd} = I_r \times \dots$	1.5	2	2.5	3	4	5	6	8	10	
Accuracy: $\pm 10\%$											
Time delay		Max resettable time: 20 ms Max break time: 80 ms									

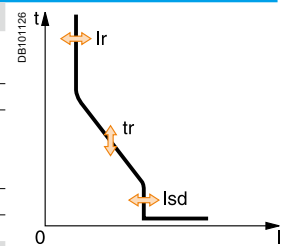

Protection		ETV5S/ETV6G										
Long time		ETV5S/ETV6G										
Current setting (A)	$I_r = I_n \times \dots$	0.4	0.5	0.6	0.7	0.8	0.9	0.95	0.98	1		
Tripping between 1.05 and 1.20 x I_r												
Time setting	tr (s)	0.5	1	2	4	8	12	16	20	24		
Time delay (s)	Accuracy: 0 to -30 %	1.5 x I_r	12.5	25	50	100	200	300	400	500	600	
	Accuracy: 0 to -20 %	6 x I_r	0.7 ⁽¹⁾	1	2	4	8	12	16	20	24	
	Accuracy: 0 to -20 %	7.2 x I_r	0.7 ⁽²⁾	0.69	1.38	2.7	5.5	8.3	11	13.8	16.6	
Thermal memory		20 minutes before and after tripping										
(1) 0 to -40 % - (2) 0 to -60 %												
Short time												
Pick-up (A)	$I_{sd} = I_r \times \dots$	1.5	2	2.5	3	4	5	6	8	10		
Accuracy: $\pm 10\%$												
Time setting tsd (s)	Settings	I^2t Off	0	0.1	0.2	0.3	0.4					
		I^2t On	-	0.1	0.2	0.3	0.4					
Time delay (ms) at 10 x I_r (I^2t Off or I^2t On)	tsd (max resettable time)		20	80	140	230	350					
	tsd (max break time)		80	140	200	320	500					
Instantaneous												
Pick-up (A)	$I_i = I_n \times \dots$	2	3	4	6	8	10	12	15	off		
Accuracy: $\pm 10\%$												
Time delay		Max resettable time: 20 ms Max break time: 50 ms										

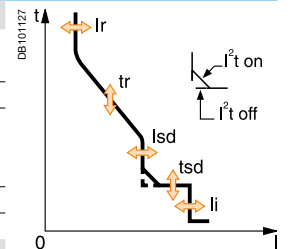

Earth fault		ETV6G										
Pick-up (A)	$I_g = I_n \times \dots$	A	B	C	D	E	F	G	H	J		
Accuracy: $\pm 10\%$	$I_n \leq 400$ A	0.3	0.3	0.4	0.5	0.6	0.7	0.8	0.9	1		
	400 A < $I_n \leq 1000$ A	0.2	0.3	0.4	0.5	0.6	0.7	0.8	0.9	1		
	$I_n \geq 1250$ A	500	640	720	800	880	960	1040	1120	1200		
Time setting tg (s)	Settings	I^2t Off	0	0.1	0.2	0.3	0.4					
		I^2t On	-	0.1	0.2	0.3	0.4					
Time delay (ms)	tg (max resettable time)		20	80	140	230	350					
	at I_n or 1200 A (I^2t Off or I^2t On)	tg (max break time)		80	140	200	320	500				

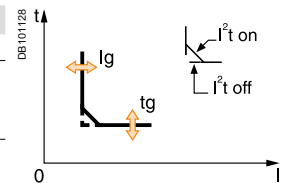

Ammeter		ETV2I/ETV5S/ETV6G		
Type of measurements		Range	Accuracy	
Instantaneous currents	I_1, I_2, I_3, I_N	0.2 x I_n to 1.2 x I_n	$\pm 1.5\%$	
	I_g (ETV6G)	0.05 x I_n to I_n	$\pm 10\%$	
Current maximeters of	I_1, I_2, I_3, I_N	0.2 x I_n to 1.2 x I_n	$\pm 1.5\%$	
Demand currents of I_1, I_2, I_3, I_g		0.2 x I_n to 1.2 x I_n	$\pm 1.5\%$	
Voltages	V12, V23, V31, V1N, V2N, V3N	100 to 690 V	$\pm 0.5\%$	
Active power	P	30 to 2000 kW	$\pm 2\%$	
Power factor	PF	0 to 1	$\pm 2\%$	
Demand power	P demand	30 to 2000 kW	$\pm 2\%$	
Active energy	Ep	-10 ¹⁰ GWh to 10 ¹⁰ GWh	$\pm 2\%$	

Note: All current-based protection functions require no auxiliary source.
The test / reset button resets maximeters, clears the tripping indication and tests the battery.

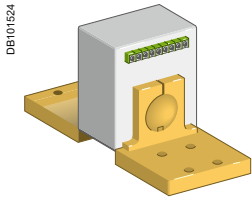

External sensor (CT).



External 24 V DC power supply module.

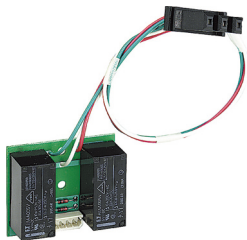

M2C.

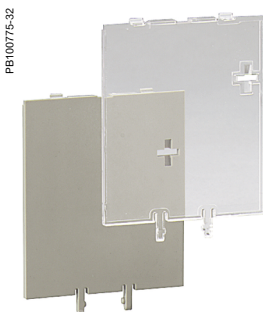

Lead-seal cover.

External sensors

External sensor for earth-fault protection

The sensors, used with the 3P circuit breakers, are installed on the neutral conductor for:

- Residual type earth-fault protection (with 6G trip units)

The rating of the sensor (CT) must be compatible with the rating of the circuit breaker:

- MVS 06 to MVS16(frame 1): TC 400/1600
- MVS 08 to MVS 20(frame 2): TC 400/2000
- MVS25 to MVS40: TC 1000/4000

Voltage measurement inputs⁽¹⁾

As standard, the control unit is supplied by internal voltage measurement inputs placed downstream of the pole for voltages between 220 and 690 V AC.

External 24 V DC power-supply module (AD)

The external power-supply module makes it possible:

- to use the display even if the circuit breaker is open or not supplied (for the exact conditions of use, see the “electrical diagrams” part of this catalogue)
- to display fault currents after tripping
- to modify settings when the circuit breaker is open (OFF position)

An external 24 V DC power supply is required for installation with communication, whatever the type of trip unit.

This module is not designed to power on 24 V DC voltage releases and electric motor mechanism.

This module powers both the control unit and the M2C programmable contacts. We recommended using the AD power supply due to its low stray primary secondary capacitance. Good operation of the Micrologic control unit in noisy environment is not guaranteed with other power supplies.

If the COM option is used, a second dedicated power supply shall be used.

This module powers both the control unit and the M2C programmable contacts.

Characteristics

- Power supply AC-to-DC or DC-to-DC
- Output voltage: 24 V DC $\pm 5\%$.
- Output current: 1 A.
- DIN rail or platine Fixing with Acti9 form factor
- Conducted emissions power line: class B per EN 61000-6-3.

M2C programmable contacts

These contacts are optional equipment for the ETV control units.

They are described with the indication contacts for the circuit breakers.

Micrologic		Type ETV
Characteristics		M2C
Minimum load		100 mA/24 V
Breaking capacity (A) p.f.: 0.7	V AC 240	5
	380	3
	V DC 24	1.8
	48	1.5
	125	0.4
	250	0.15

M2C: 24 V DC power supplied by control unit (consumption 100 mA).

Spare parts

Lead-seal covers

A lead-seal cover controls access to the adjustment dials.

When the cover is closed:

- The test connector remains accessible
- The test button for the earth-fault protection function remains accessible

Characteristics

- Transparent cover for all trip units

Spare battery

A battery supplies power to the LEDs identifying the tripping causes. The healthiness of the battery to be checked periodically. A test button on the front of the control unit is used to check the battery condition. The battery may be replaced on site when discharged.

⁽¹⁾ Refer to EasyPact MVS user manual on using 3 pole circuit breakers in 4 wire system with ETV trip system for Energy measurement.

Eco COM transmits metering data and status. It is not used to communicate controls.

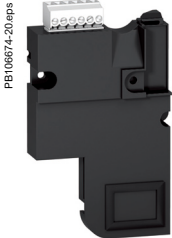

BCM ULP.



I/O application module.

For fixed and Drawout devices, the common communication option is made up of:

- a BCM ULP module, installed behind the Trip System and supplied with its set of sensors (OF, SDE, PF and CH micro switches) and its COM terminal block (inputs E1 to E6). This module is independent of the control unit. It receives and transmits information on the communication network. An infra-red link transmits data between the control unit and the communication module.

Consumption: 30 mA, 24 V.

- IFM, this module required for connection to the network, contains the Modbus address (1 to 99) declared by the user via the two dials in front. It automatically adapts (baud rate, parity) to the Modbus network in which it is installed.

For drawout device the Cradle Management option must be added:

I/O (Input/Output) application module for LV breaker, the I/O application module is delivered with withdrawable devices ordered with the COM option, for cradle management. It must be installed on a DIN rail near the device. It must be connected to the ULP system and to the position contacts (CD, CT, CE) that transmit the position of the device in the cradle.

IFM Modbus communication interface



IFM Modbus communication interface.
Ref.: LV434000.

Function

A IFM - Modbus communication interface - is required for connection of a Masterpact or Easycompact to a Modbus network as long as this circuit breaker is provided with a ULP (Universal Logic Plug) port. The port is available on respectively a BCM ULP.

The IFM is defined as an IMU (Intelligent Modular Unit) in the ULP connection System documentation.

Once connected, the circuit breaker is considered as a slave by the Modbus master. Its electrical values, alarm status, open/close signals can be monitored or controlled by a Programmable Logic Controller or any other system.

Characteristics

ULP port

2 RJ45 sockets, internal parallel wiring.

- Connection of a single circuit breaker (eventually via its I/O application module).
 - A ULP line terminator must be connected to the second RJ45 ULP socket. The RJ45 sockets deliver a 24 VDC supply fed from the Modbus socket.
- Built-in test function, for checking the correct connection to the circuit breaker.

Modbus slave port

- Top socket for screw-clamp connector, providing terminals for:
 - 24 VDC input supply (0V, +24V)
 - Modbus line (D1, D2, Gnd).
 - Lateral socket, for Din-rail stackable connector.
- Both top and lateral sockets are internally parallel wired.
- Multiple IFM can be stacked, thus sharing a common power supply and Modbus line without individual wiring.
 - On the front face:
 - Modbus address setting (1 to 99): 2 coded rotary switches
 - Modbus locking pad: enables or disable the circuit breaker remote control and modification of IFM parameters.
 - Self adjusting communication format (Baud rate, parity).

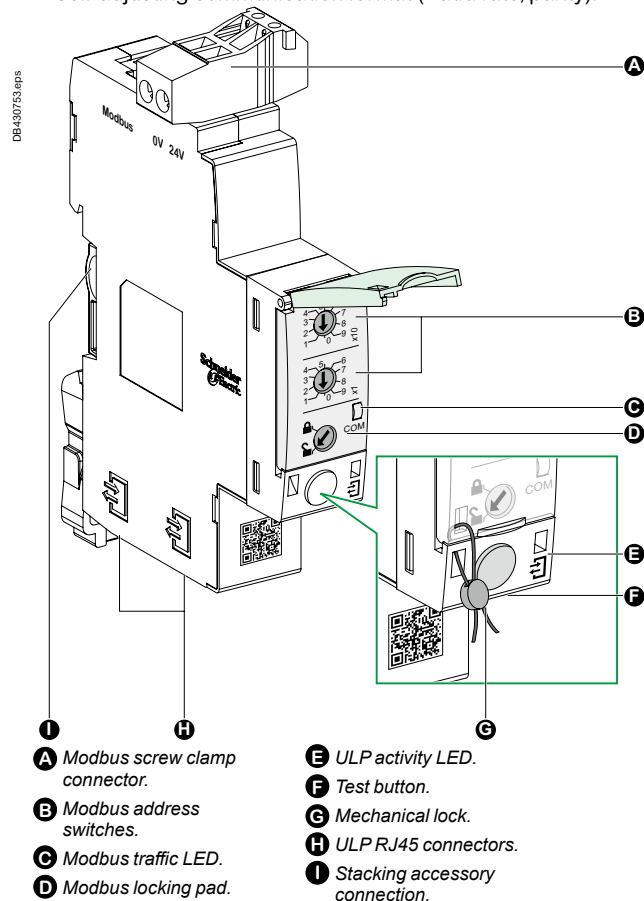

Technical characteristics

IFM Modbus communication interface

Dimensions	18 x 72 x 96 mm	
Maximum number of stacked IFM	12	
Degree of protection of the installed module	Part projecting beyond the escutcheon	IP4x
	Other module parts	IP3x
	Connectors	IP2x
Operating temperature	-25...+70 °C	
Power supply voltage	24 V DC -20 %/+10 % (19.2...26.4 V DC)	
Consumption	Typical	21 mA/24 V DC at 20 °C
	Maximum	30 mA/19.2 V DC at 60 °C
Certification		
CE	IEC/EN 60947-1	
UL	UL 508 - Industrial Control Equipment	
CSA	No. 142-M1987 - Process Control Equipment ■ CAN/CSA C22.2 No. 0-M91 - General requirements - Canadian Electrical Code Part ■ CAN/CSA C22.2 No. 14-05 - Industrial Control Equipment	

Simplified IFM installation

Stacking IFM

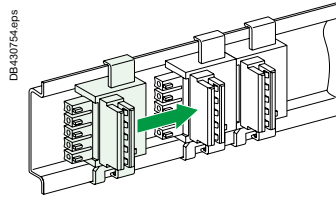

Stacking accessories

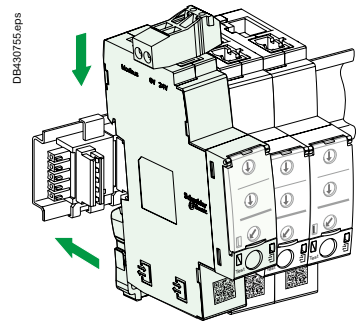

Up to 12 stacked IFM

Electrical operated

Fixed device

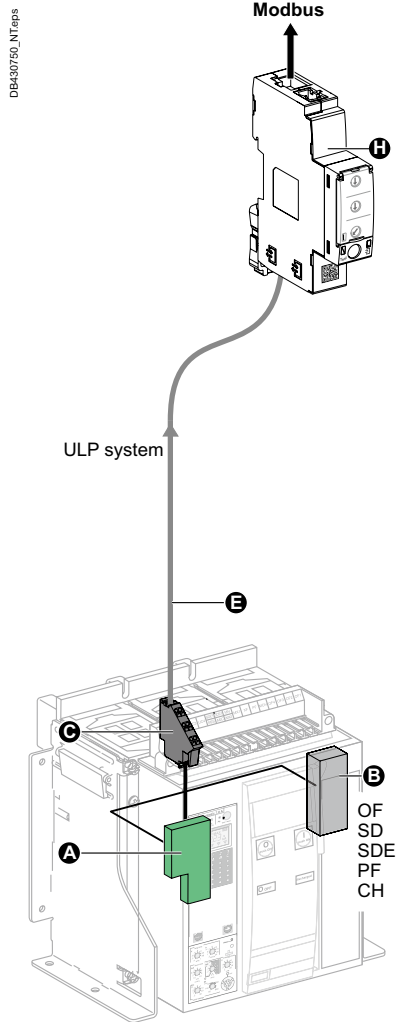

- A** BCM ULP
- B** OF, SDE ... microswitches
- C** COM terminal block (E1 to E6)

Drawout device

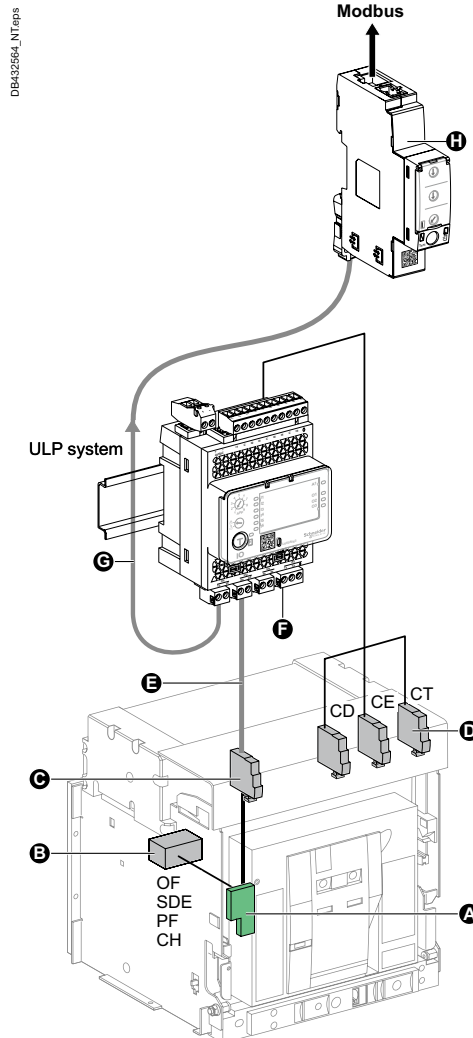

- E** Breaker ULP cord
- F** I/O application module
- G** ULP cable
- H** IFM module

PB119234.eps



Description

The I/O input/output application module for LV breaker is part of an ULP system with built-in functionalities and applications to enhance the application needs. The ULP system architecture can be built without any restrictions using the wide range of circuit breakers. The I/O application is compliant with the ULP system specifications. Two I/O application module can be connected in the same ULP network.

The ranges of LV circuit breakers enhanced by the I/O are:

- Masterpact NT/NW
- EasyPact MVS
- Compact NS1600b-3200
- Compact NS630b-1600
- Compact NSX100-630 A.

I/O input/output interface for LV breaker resources

The I/O application module resources are:

- 6 digital inputs that are self powered for either NO and NC dry contact or pulse counter
- 3 digital outputs that are bistable relay (5 A maximum)
- 1 analog input for Pt100 temperature sensor.

Pre-defined applications

Pre-defined application adds new functions to the IMU in a simple way:

- selection by the application rotary switch on the I/O, defining the application with pre-defined input/output assignment and wiring diagram.
- no additional setting with the customer engineering tool required.

The resources not assigned to the pre-defined application are free for additional user-defined applications:

- cradle management
- breaker operation
- light and load control
- custom.

User-defined applications

User-defined applications are processed by the I/O in addition to the pre-defined application selected.

The user-defined applications are available depending on:

- the pre-defined application selected
- the I/O resources (inputs and outputs) not used by the application.

The resources required by user-defined applications are assigned using the customer engineering tool:

- protection
- control
- energy management
- monitoring.

Mounting

The I/O is a DIN rail mounting device.

Application rotary switch

The application rotary switch enables the selection of the pre-defined application.

It has 9 positions and each position is assigned to a pre-defined application.

The factory set position of the switch is pre-defined application 1.

Setting locking pad

The setting locking pad on the front panel of the I/O enables the setting of the I/O by the customer engineering tool.

DB418827.eps

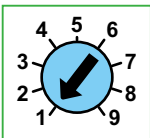

DB418828.eps

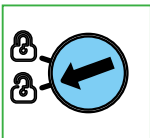

DB418828.eps

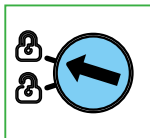

DB419233.eps

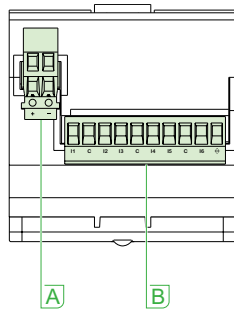

DB432536.eps

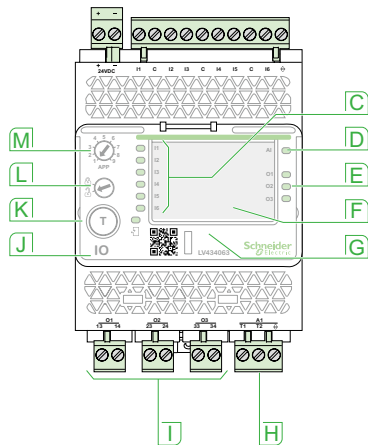

DB419235.eps

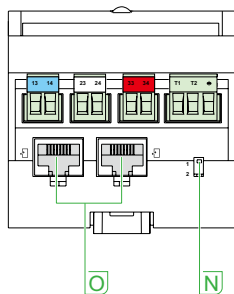

- A** 24 Vdc power supply terminal block.
- B** Digital input terminal block: 6 inputs, 3 commons and 1 shield.
- C** 6 input status LEDs.
- D** Analog input status LED.
- E** 3 output status LEDs.
- F** I/O application module identification labels.
- G** Sealable transparent cover.
- H** Analog input terminal block.
- I** Digital output terminal blocks.
- J** ULP status LED.
- K** Test/reset button (accessible with cover closed).
- L** Setting locking pad.
- M** Application rotary switch: 1 to 9.
- N** Switch for I/O addressing (I/O 1 or I/O 2).
- O** ULP connectors.

General characteristics

Environmental characteristics

Conforming to standards	UL 508, UL 60950, IED 60950, 60947-6-2
Certification	cUIUs, GOST, FCC, CE
Ambient temperature	-20 to +70 °C (-4 to +158 °F)
Relative humidity	5–85 %
Level of pollution	Level 3
Flame resistance	ULV0

Mechanical characteristics

Shock resistance	1000 m/s ²
Resistance to sinusoidal vibrations	5 Hz < f < 8.4 Hz

Electrical characteristics

Resistance to electromagnetic discharge	Conforming to IEC/EN 61000-4-3
Immunity to radiated fields	10 V/m
Immunity to surges	Conforming to IEC/EN 61000-4-5
Consumption	165 mA

Physical characteristics

Dimensions	71.7 x 116 x 70.6 mm (2.83 x 4.56 x 2.78 in.)
Mounting	DIN rail
Weight	229.5 g (0.51 lb)

Degree of protection of the installed I/O application module	<ul style="list-style-type: none"> ■ On the front panel (wall mounted enclosure): IP4x ■ IO parts: IP3x ■ Connectors: IP2x
--	---

Connections	Screw type terminal blocks
-------------	----------------------------

Technical characteristics - 24 V DC power supply

Power supply type	Regulated switch type
Rated power	72 W
Input voltage	100–120 V AC for single phase 200–500 V AC phase-to-phase
PFC filter	With IEC 61000-3-2
Output voltage	24 V DC
Power supply out current	3 A

Note: it is recommended to use an UL listed/UL listed recognized limited voltage/Limited current or a class 2 power supply with a 24 V DC, 3 A maximum.

Digital inputs

Digital input type	Self powered digital input with current limitations as per IEC 61131-2 type 2 standards (7 mA)
Input limit values at state 1 (close)	19.8–25.2 V DC, 6.1–8.8 mA
Input limit values at state 0 (open)	0–19.8 V DC, 0 mA
Maximum cable length	10 m (33 ft)

Note: for a length greater than 10 m (33 ft) and up to 300 m (1,000 ft), it is mandatory to use a shielded twisted cable. The shield cable is connected to the I/O functional ground of the I/O application module.

Digital outputs

Digital output type	Bistable relay
Rated load	5 A at 250 V AC
Rated carry current	5 A
Maximum switching voltage	380 V AC, 125 V DC
Maximum switch current	5 A
Maximum switching power	1250 VA, 150 W
Minimum permissible load	10 mA at 5 V DC
Contact resistance	30 mΩ
Maximum operating frequency	<ul style="list-style-type: none"> ■ 18000 operations/hr (Mechanical) ■ 1800 operations/hr (Electrical)
Digital output relay protection by an external fuse	External fuse of 5 A or less
Maximum cable length	10 m (33 ft)

Analog inputs

The I/O application module analog input can be connected to a Pt100 temperature sensor		
Range	-30 to 200 °C	-22 to 392 °F
Accuracy	±2 °C from -30 to 20 °C	±3.6 °F from -22 to 68 °F
	±1 °C from 20 to 140 °C	±1.8 °F from 68 to 284 °F
	±2 °C from 140 to 200 °C	±3.6 °F from 284 to 392 °F
Refresh interval	5 s	5 s

Connection of the IFM & I/O module to a fixed or drawout EasyPact MVS or circuit breaker using the breaker ULP cord

Connect the IFM to a fixed electrically operated EasyPact MVS or circuit breaker using the breaker ULP cord

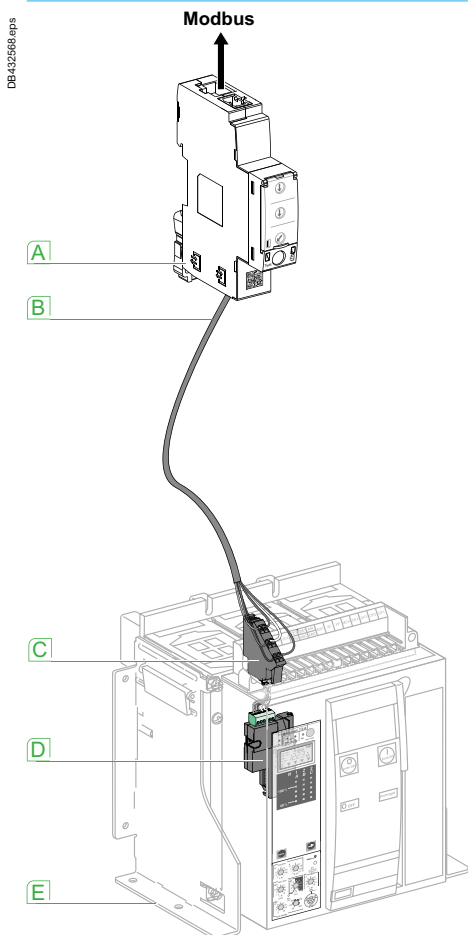

- A** IFM Modbus interface for LV circuit breaker
- B** Breaker ULP cord
- C** Fixed terminal block
- D** BCM ULP communication module
- E** Fixed electrically operated circuit breaker

Connect the IFM to a drawout EasyPact MVS or circuit breaker using the breaker ULP cord

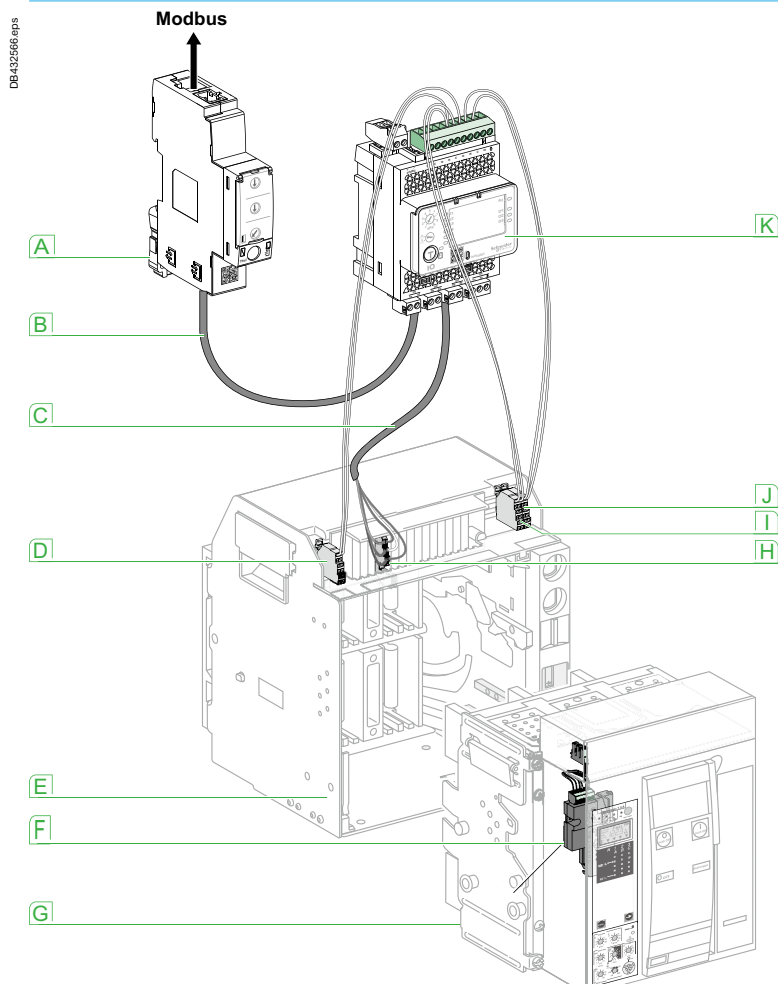

- A** IFM Modbus interface for LV circuit breaker
- B** ULP cable
- C** Breaker ULP cord
- D** Circuit breaker disconnected position contact (CD)
- E** Circuit breaker cradle
- F** BCM ULP communication module
- G** Drawout circuit breaker
- H** Drawout terminal block
- I** Circuit breaker connected position contact (CE)
- J** Circuit breaker test position contact (CT)
- K** I/O (Input/Output) application module for LV circuit breaker

EasyCom Communication

Overview

EasyCom Communication module allows you to connect and control the air circuit breakers over Modbus communication architecture.

Resources(Inputs/Outputs)

The Communication module resources are:

- Nine digital inputs
- Six digital outputs
- One analog inout



Key Features

The main features of the communication module are:

- **Ensures to make communication architecture affordable and easily maintainable**
- **Connects, controls, and manages up to three circuit breakers.**
 - connect: Breaker ON/OFF status (OF), Breaker Trip status (SDE), Ready To Close status (PF)
 - Control: Remote Oper/Close of EasyPact air circuit breakers
 - Manage: One Analog Input for temperature measurement (4...20mA)

Safety Operation

The communication module keeps safety as its top priority while you control the communication architecture.

- During maintenance, the local operator can switch off the remote operation module locally. The remote operator can see the status of the air circuit breaker from remote, but cannot give the ON/OFF command.
- The communication module provides 'ready-to-close' indication on the communication network, keeping the safety of the operator and installation on priority.
- The operator must check the following status of the air breaker before the ON command is given to the circuit breaker through the communication architecture.
 - The circuit breaker is in the OFF position.
 - The Spring mechanism is charged.
 - A maintained opening order is not present.
 - The tripping command is not present through shunt, under voltage.
 - The air circuit breaker is completely rack in or not.
 - The air circuit breaker is locked in the Off position or is mechanically interlock with any other air circuit breaker.

The EasyPact air circuit breaker is equipped with a 'ready-to-close' accessory that helps to check these conditions from remote on the communication architecture. Once it is fulfilled, the ON command is given to the circuit breaker.

Commnuication Architecture

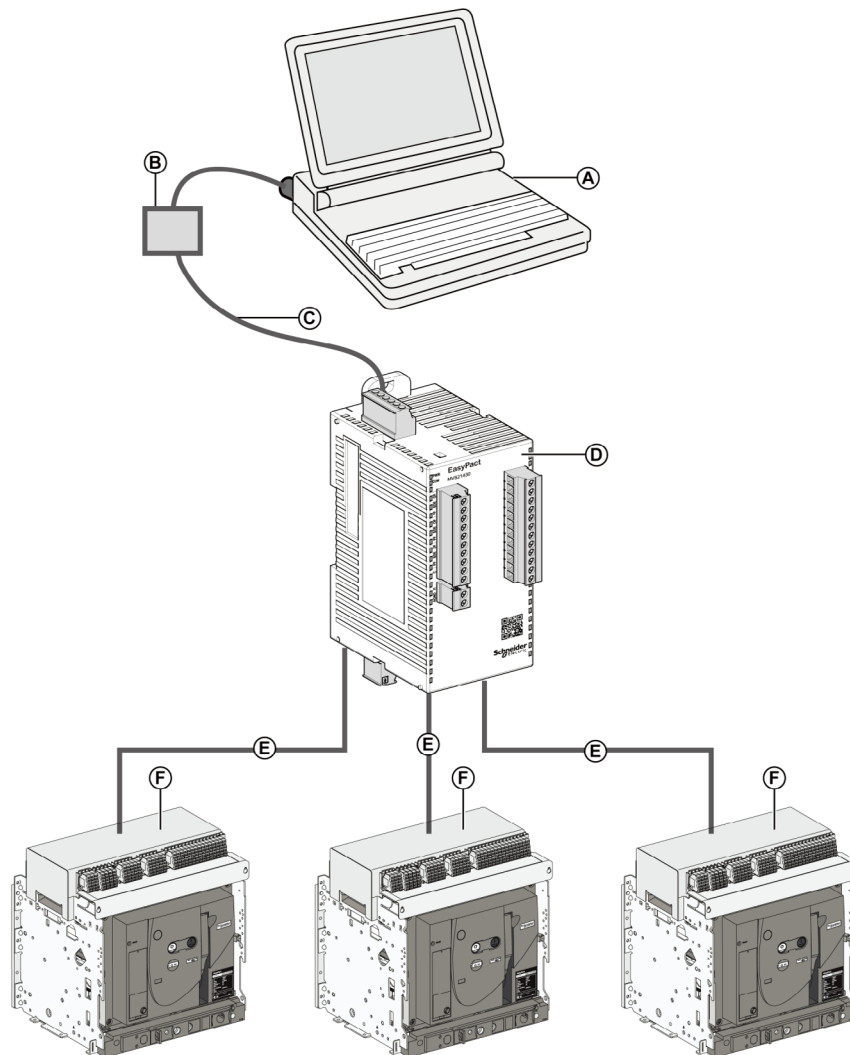

- A Customer Scope Modbus Master/SCADA Supervisor**
- B Customer Scope Modbus communication cable (RS 485 cable)**
- C Customer Scope Modbus to USB/converter**
- D EasyCom Communication module**
- E Digital input/Digital Output wires**
- F EasyPact MVS**

Hardware Description

Description

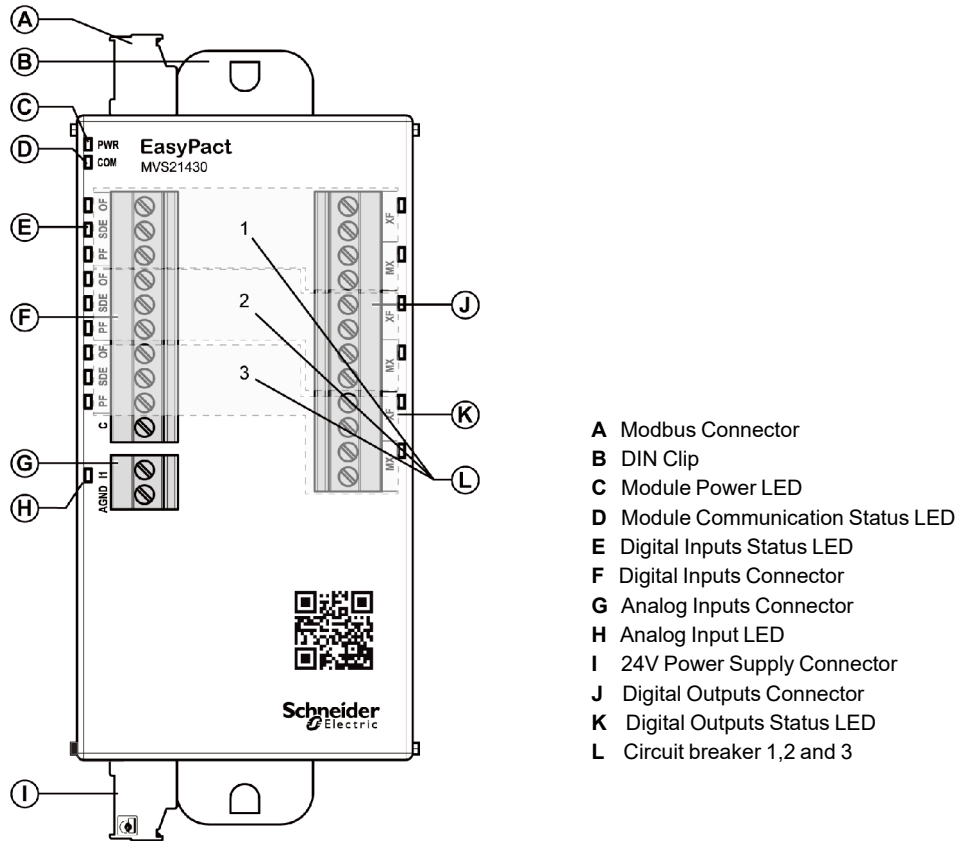

- A Modbus Connector
- B DIN Clip
- C Module Power LED
- D Module Communication Status LED
- E Digital Inputs Status LED
- F Digital Inputs Connector
- G Analog Inputs Connector
- H Analog Input LED
- I 24V Power Supply Connector
- J Digital Outputs Connector
- K Digital Outputs Status LED
- L Circuit breaker 1,2 and 3

Mounting

EasyCom Communication module mounts on a DIN rail(Reference: Top hat rail EN50022/TS35). Pull the sliders provided with the unit towards the outward direction. Rest the unit on the DIN rail plate. Pull down the slider again so that the unit gets fixed on the DIN rail plate

24 Vdc Power Supply

It is recommended to use UL listed/UL recognized limited voltage/limited current or a Class 2 Power supply with a 24 Vdc, 3A maximum and with the shield pin connection.

Module Power LED

Marking on the product	LED Indication	Status Description
PWR	ON	Module is powered
	OFF	Module is not powered

Module Communication Status L

Marking on the product	LED Indication	Status Description
COM	ON	Communication established
	Blink	Communication established
	OFF	No Communication

Digital Input status LED

Marking on the product	LED Indication	Status Description
3X(OFSDE,PF)	ON	Input is high
	OFF	Input is low

Digital Output status LED

Marking on the product	LED Indication	Status Description
3X(OFSDE,PF)	ON	Relay output is CLOSE
	OFF	Relay output is OPEN

Analog Input status LED

Marking on the product	LED Indication	Status Description
AI	ON	4...20 mA range Input
	OFF	No sensor
	1s ON, 1s OFF	Out of range input

Connections

Overview of solutions and accessories

Available connection:

- Rear connections: horizontal, vertical and mixed
- The solutions presented are similar in principle for all EasyPact MVS fixed and draw-out devices.

Rear connection

Horizontal

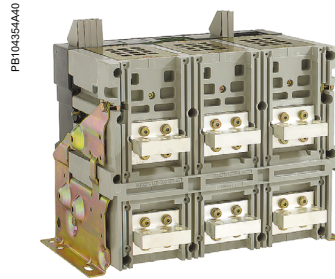

Vertical

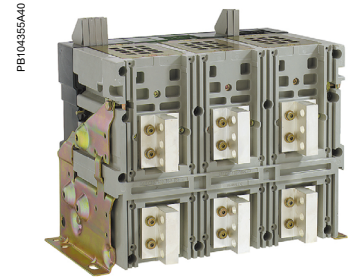

Mixed

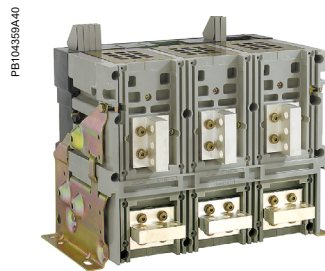

Simply turn a horizontal rear connector 90° to make it a vertical connector.

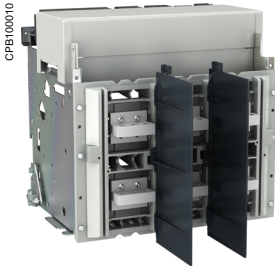

Interphase barriers EIP

These barriers are flexible insulated partitions used to reinforce isolation of connection points in installations with busbars, whether insulated or not. For EasyPact MVS devices, they are installed vertically between rear connection terminals. They are not compatible with spreaders.



Safety shutters VO

Mounted on the chassis, the safety shutters automatically block access to the disconnecting contact cluster when the device is in the disconnected or test positions

(degree of protection IP 20) When the device is removed from its chassis, no live parts are accessible.

The shutter-locking system is made up of a moving block (optional device) that can be padlocked (padlock not supplied). The block:



- Prevents connection of the device
- Locks the shutters in the closed position



For EasyPact MVS06 to MVS40

A support at the bottom of the chassis is used to store the blocks when they are not used:

- 2 blocks for MVS06 to MVS40

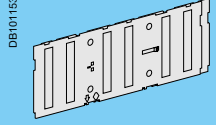
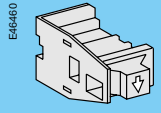
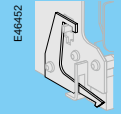
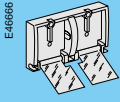
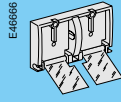
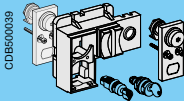
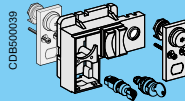
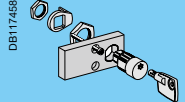
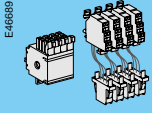
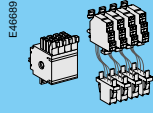
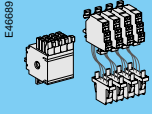
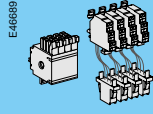
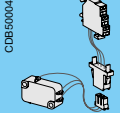
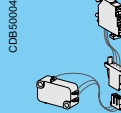
Accessories and auxiliaries

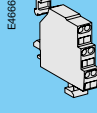
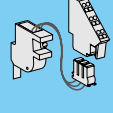
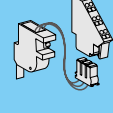
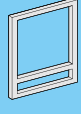
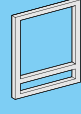
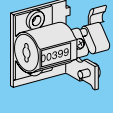
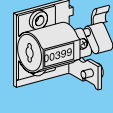
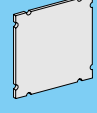
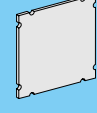
Type of accessory	EasyPact MVS06 to MVS40	
	Fixed breaker Rear connection	Draw-out breaker Rear connection
Interphase barriers	 DB101149 Optional	 DB101149 Optional
Safety shutters		 DB101153 Standard
Safety shutters locking blocks		 E46460 Optional
Door interlock		 E46452 Optional
Pushbutton locking device	 E46686 Optional	 E46686 Optional
OFF position locking	 CDB500039 Optional	 CDB500039 Optional
“Disconnected” position locking		 DB117458 Optional
ON/OFF indication contacts(OF)	 E46689 Standard	 E46689 Standard
Additional ON/OFF indication contacts(OF) not incl MVS frame 1	 E46689 Optional	 E46689 Optional
“Fault trip” indication contact(SDE)	 CDB500040 Standard	 CDB500040 Standard

Type of accessory	EasyPact MVS06 to MVS40	
	Fixed breaker Rear connection	Draw-out breaker Rear connection
“Connected, disconnected, test position” indication contact(CE,CD,CT)		 Optional
“Ready to close” contact(PF)	 Optional	 Optional
Escutcheon(CDP)	 Standard	 Standard
Mechanical operation counter(CDM) not incl MVS frame 1	 Optional	 Optional
Escutcheon blanking plate	 Optional	 Optional
Auxiliary terminal shield(CB)		 Optional
Transparent cover (IP54)		 Optional

Locking

On the device

- 1 Reset button for mechanical trip indication.
- 2 OFF pushbutton.
- 3 OFF position lock.
- 4 Door interlock.
- 5 ON pushbutton.
- 6 Spring charge indication.
- 7 Pushbutton locking.
- 8 Contact position indication.
- 9 Operation counter.

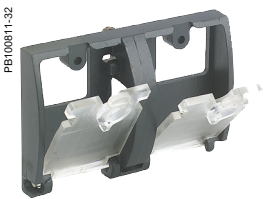
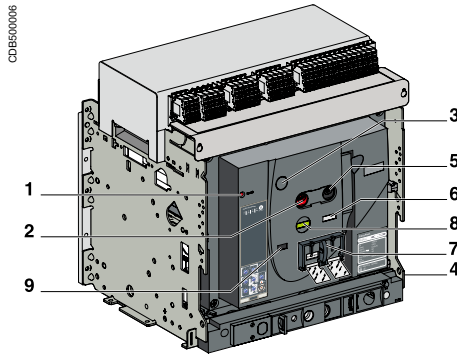

Access to pushbuttons protected by transparent cover.



Pushbutton locking using a padlock.



OFF position locking using a keylock.

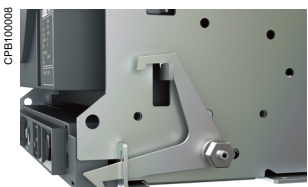

Door interlock.

Pushbutton locking VBP

The transparent cover blocks access to the pushbuttons used to open and close the device.

It is possible to independently lock the opening button and the closing button. The locking device is often combined with a remote operating mechanism.

The pushbuttons may be locked using either:

- Three padlocks (not supplied)
- Lead seal
- Two screws

Device locking in the OFF position by keylocks VSPO

The circuit breaker is locked in the OFF position by physically maintaining the opening pushbutton pressed down:

- Using keylocks (one or two keylocks, supplied)

Keys may be removed only when locking is effective (Profalux or Ronis type locks).

The keylocks are available in any of the following configurations:

- One keylock
- One keylock mounted on the device + one identical keylock supplied separately for interlocking with another device

A locking kit (without locks) is available for installation of one or two keylocks (Ronis, Profalux).

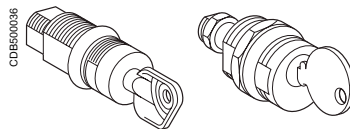

Profalux

Ronis

Door interlock catch VPEC

Mounted on the right or left-hand side of the chassis, this device inhibits opening of the cubicle door when the circuit breaker is in "connected" or "test" position. If the breaker is put in the "connected" position with the door open, the door may be closed without having to disconnect the circuit breaker.

Automatic spring discharge before breaker removal DAE

This option discharges the springs before the breaker is removed from the chassis.

Locking On the chassis

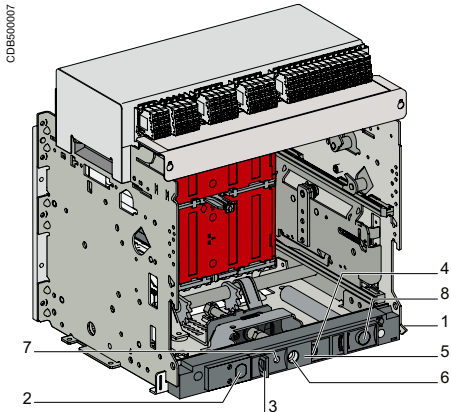

- 1 Door interlock.
- 2 Keylock locking.
- 3 Padlock locking.
- 4 Position indicator.
- 5 Chassis front plate (accessible with cubicle door closed).
- 6 Racking-handle entry.
- 7 Release button.
- 8 Racking-handle storage.

“Connected”, “disconnected” and “test” position racking interlock

The “connected”, “disconnected” and “test” positions are shown by an indicator and are mechanically indexed. The exact position is obtained when the racking handle blocks. A release button is used to free it.

“Disconnected” position locking by padlocks or keylocks VSPD

Mounted on the chassis and accessible with the door closed, these devices lock the circuit breaker in the “disconnected” position in two manners:

- Using padlocks (standard), up to three padlocks (not supplied)
 - Using keylocks (optional), one or two different keylocks are available
- Profalux and Ronis keylocks are available in different options:
- One keylock
 - Two identical key locks - one keylock mounted on the device + one identical keylock supplied separately for interlocking with another device
- A locking kit (without locks) is available for installation of one or two keylocks (Ronis, Profalux).

Padlock

Circuit breaker in “disconnected” position.

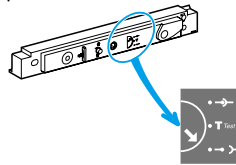

Insert the shackle (max. diameter 5 to 8 mm) of the padlock(s).

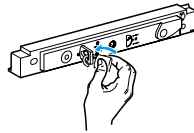

Pull out the tab.

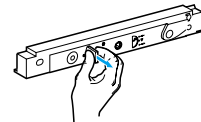

The crank cannot be inserted.

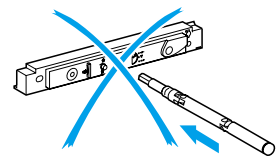

Keylock

Circuit breaker in “disconnected” position.

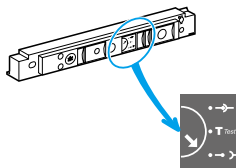

Remove the key(s)

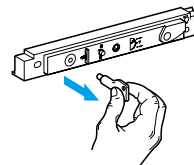

Turn the key(s).

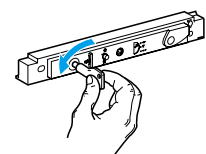

The crank cannot be inserted.

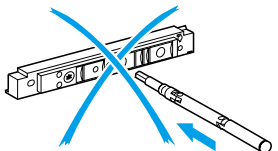

“Disconnected” position locking by padlock.



“Disconnected” position locking by keylock.

Indication contacts

Indication contacts are available:

- in the standard version for relay applications

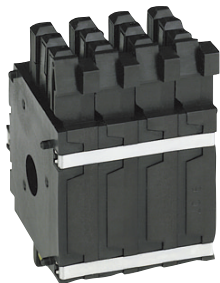

ON/OFF indication contacts (OF) (rotary type).

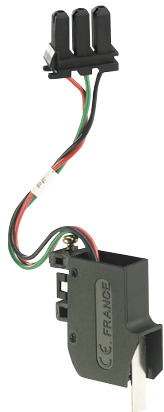

"Fault-trip" indication contact (SDE).

ON/OFF indication contacts OF

Indication contacts indicate the ON or OFF position of the circuit breaker:

- Rotary type changeover contacts directly driven by the mechanism for EasyPact MVS. These contacts trip when the minimum isolation distance between the main circuit-breaker contacts is reached

OF		Frame 1	Frame 2		
Supplied as standard		4	4		
Maximum number		4	12		
Breaking capacity (A) p.f.: 0.3 AC12/DC12	Standard	Minimum load: 100 mA/24 V			
		V AC	240/380	6	10/6 ⁽¹⁾
			480	6	10/6 ⁽¹⁾
		690	6	6	
	V DC	24/48	2.5	10/6 ⁽¹⁾	
		125	0.5	10/6 ⁽¹⁾	
		250	0.3	3	
	Low-level	Minimum load: 2 mA/15 V			
	V AC	24/48	5	6	
		240	5	6	
	380	5	3		
V DC	24/48	5/2.5	6		
	125	0.5	6		
	250	0.3	3		

⁽¹⁾ Standard contacts: 10 A; optional contacts: 6 A.

"Fault-trip" indication contacts SDE

Circuit-breaker tripping due to a fault is signalled by:

- A red mechanical fault indicator (reset)
- One changeover contact SDE

Following tripping, the mechanical indicator must be reset before the circuit breaker may be closed. One SDE is supplied as standard.

SDE		MVS		
Supplied as standard		1		
Maximum number		2		
Breaking capacity (A) p.f.: 0.3 AC12/DC12	Standard	Minimum load: 100 mA/24 V		
		V AC	240/380	6
			480	2
	V DC	24/48	3	
		125	0.3	
		250	0.15	
	Low-level	Minimum load: 2 mA/15 V		
	V AC	24/48	3	
		240	3	
		380	3	
V DC	24/48	3		
	125	0.3		
	250	0.15		

Indication contacts

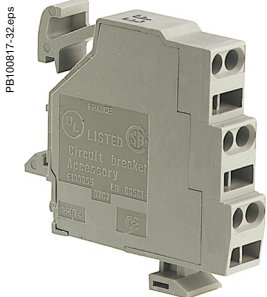

CE, CD and CT "connected/disconnected/test" position carriage switches.

"Connected", "disconnected" and "test" position carriage switches CE, CD & CT

Three series of optional auxiliary contacts are available for the chassis:

- Changeover contacts to indicate the "connected" position CE
- Changeover contacts to indicate the "disconnected" position CD. This position is indicated when the required clearance for isolation of the power and auxiliary circuits is reached
- Changeover contacts to indicate the "test" position CT. In this position, the power circuits are disconnected and the auxiliary circuits are connected

		MVS frame 1			MVS Frame 2		
Contacts		CE/CD/CT			CE/CD/CT		
Maximum number	Standard with additional actuators	3	2	1	3	3	3
		9	0	0	6	3	0
		6	3	0	6	0	3
		3	0	3	3	6	0
Breaking capacity (A) p.f.: 0.3 AC12/DC12	Standard	Minimum load: 100 mA/24 V					
		V AC	240	8		8	
			380	8		8	
			480	8		8	
		V DC	24/48	2.5		2.5	
			125	0.8		0.8	
	250		0.3		0.3		
	Low-level	Minimum load: 2 mA/15 V					
		V AC	24/48	5		5	
			240	5		5	
			380	5		5	
		V DC	24/48	2.5		2.5	
125			0.8		0.8		
250	0.3			0.3			

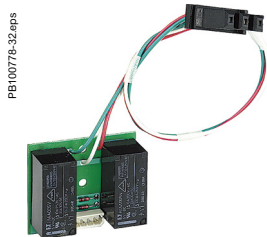

M2C programmable contacts: circuit breaker internal relay with two contacts.

M2C programmable contacts

These contacts, used with the ETV control units, may be programmed via the control unit keypad or via a supervisory station with the COM communication option. They require an external power supply module.

The M2C (two contacts) auxiliary contacts may be used to signal threshold overruns or status changes. They can be programmed using the COM option (BCM ULP).

Micrologic		Type ETV
Characteristics		M2C
Minimum load		100 mA/24 V
Breaking capacity (A) p.f.: 0.7	V AC	240
		380
V DC	24	1.8
	48	1.5
	125	0.4
	250	0.15

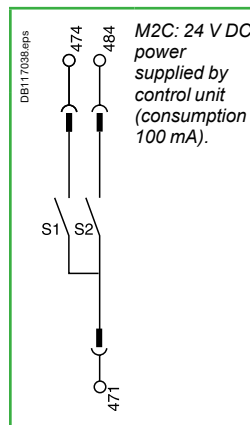

A point-to-point solution for remote operation of EasyPact MVS

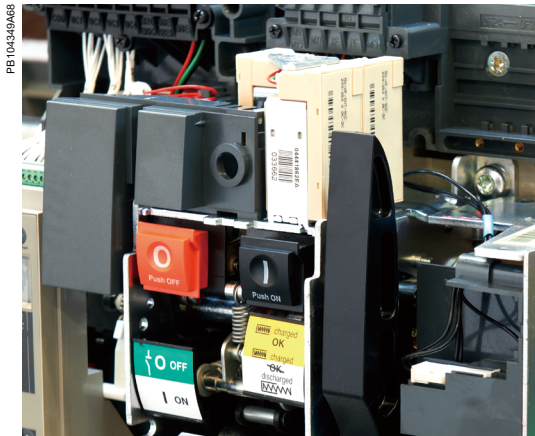

Note: An opening order always takes priority over a closing order.
 If opening and closing orders occur simultaneously, the mechanism discharges without any movement of the main contacts. The circuit breaker remains in the open position (OFF).
 In the event of maintained opening and closing orders, the standard mechanism provides an anti-pumping function by blocking the main contacts in open position.
 Anti-pumping function. After fault tripping or intentional opening using the manual or electrical controls, the closing order must first be discontinued, then reactivated to close the circuit breaker.

The remote ON / OFF function is used to remotely open and close the circuit breaker.

It is made up of:

- An electric motor MCH equipped with a “springs charged” limit switch contact CH
- Two voltage releases:
 - A closing release XF
 - An opening release MX

Optionally, other function may be added:

- A “ready to close” contact PF

A remote-operation function is generally combined with:

- Device ON / OFF indication OF
- “Fault-trip” indication SDE

Wiring diagram of a point-to-point remote ON / OFF function

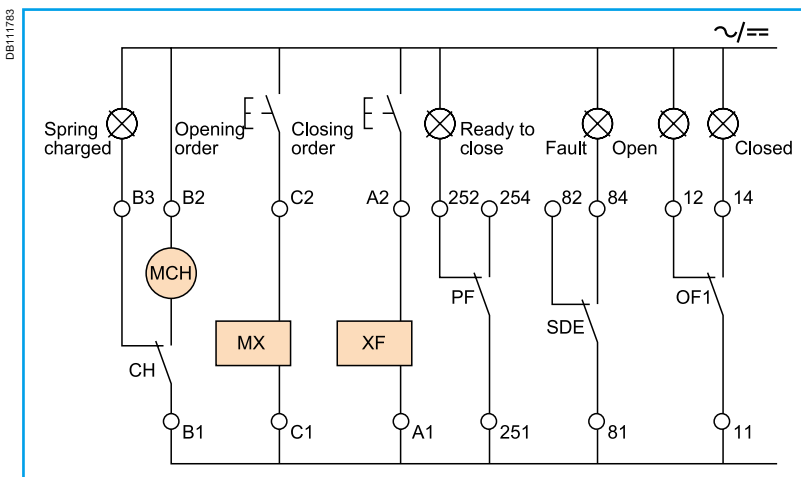

Remote operation

Remote ON / OFF



Electric motor MCH for EasyPact MVS.

Electric motor MCH

The electric motor automatically charges and recharges the spring mechanism when the circuit breaker is closed. Instantaneous reclosing of the breaker is thus possible following opening. The spring-mechanism charging handle is used only as a backup if auxiliary power is absent. The electric motor MCH is equipped as standard with a limit switch contact CH that signals the “charged” position of the mechanism (springs charged).

Characteristics

Power supply	V AC 50/60 Hz	100/130 - 200/240 - 380/415
	V DC	24/30 - 48/60 - 100/125 - 200/250
Operating threshold	0.85 to 1.1 Un	
Consumption (VA or W)	180	
Motor overcurrent	2 to 3 In for 0.1 s	
Charging time	Maximum 4 s	
Operating frequency	Maximum 3 cycles per minute	
CH contact	10 A at 240 V	

Voltage releases XF and MX

Their supply can be maintained or automatically disconnected.

Closing release XF

The XF release remotely closes the circuit breaker if the spring mechanism is charged.

Opening release MX

The MX release instantaneously opens the circuit breaker when energised. It locks the circuit breaker in OFF position if the order is maintained.

Characteristics

Characteristics	XF	MX
Power supply	V AC 50/60 Hz	24 - 48 - 100/130 - 200/250 - 380/480
	V DC	12 - 24/30 - 48/60 - 100/130 - 200/250
Operating threshold	0.85 to 1.1 Un	
Consumption (VA or W)	Hold: 4.5	Hold: 4.5
	Pick-up: 200 (200 ms)	Pick-up: 200 (200 ms)
Circuit-breaker response time at Un	70 ms ±10	50 ms ±10

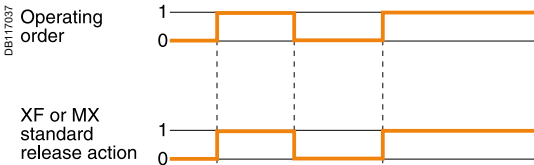

MX voltage releases.



XF voltage release.

“Ready to close” contact PF

The “ready to close” position of the circuit breaker is indicated by a mechanical indicator and a PF changeover contact. This signal indicates that all the following are valid:

- The circuit breaker is in the OFF position
- The spring mechanism is charged
- A maintained opening order is not present:
 - MX energised
 - Fault trip
 - Remote tripping MN
 - Device not completely racked in
 - Device locked in OFF position
 - Device interlocked with a second device

Characteristics

Maximum number	1	
Breaking capacity (A)	Standard	Minimum load: 100 mA/24 V
	p.f.: 0.3	V AC
AC12/DC12	240/380	5
	480	5
	690	3
	V DC	24/48
	125	0.3
	250	0.15

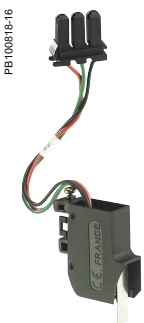

“Ready to close” contacts PF.

DB100809-16



MN voltage release.

056422N

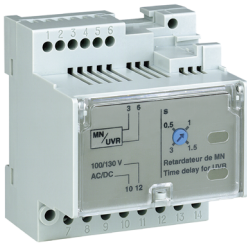

MN delay unit.

Instantaneous voltage releases MN

The MN release instantaneously opens the circuit breaker when its supply voltage drops to a value between 35 % and 70 % of its rated voltage. If there is no supply on

the release, it is impossible to close the circuit breaker, either manually or electrically.

Any attempt to close the circuit breaker has no effect on the main contacts. Circuit breaker closing is enabled again when the supply voltage of the release returns to 85% of its rated value.

Characteristics

Power supply	V AC 50/60 Hz	24 - 48 - 100/130 - 200/250 - 380/480	
	V DC	24/30 - 48/60 - 100/130 - 200/250	
Operating threshold	Opening	0.35 to 0.7 Un	
	Closing	0.85 Un	
Consumption (VA or W)		Pick-up: 200 (200 ms)	Hold: 4.5
MN consumption with delay unit (VA or W)		Pick-up: 200 (200 ms)	Hold: 4.5
Circuit-breaker response time at Un		90 ms ±5	

MN delay units

To eliminate circuit-breaker nuisance tripping during short voltage dips, operation of

the MN release can be delayed. This function is achieved by adding an external delay unit in the MN voltage-release circuit. Two versions are available, adjustable and non-adjustable.

Characteristics

Power supply	Non-adjustable	100/130 - 200/250	
	Adjustable	48/60 - 100/130 - 200/250 - 380/480	
Operating threshold	Opening	0.35 to 0.7 Un	
	Closing	0.85 Un	
Delay unit consumption		Pick-up: 200 (200 ms)	Hold: 4.5
Circuit-breaker response time at Un	Non-adjustable	0.25 s	
	Adjustable	0.5 s - 0.9 s - 1.5 s - 3 s	

Source-changeover systems

Mechanical interlocking

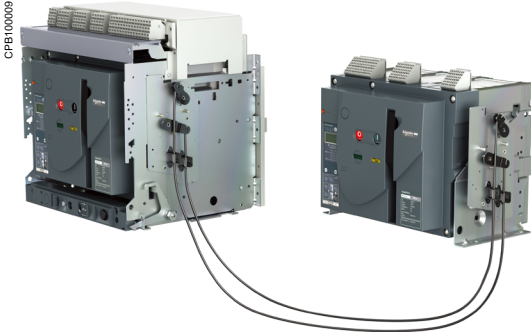

Interlocking of two EasyPact circuit breakers using cable.

Interlocking of two EasyPact MVS or up to three EasyPact MVS devices using cables

For cable interlocking, the circuit breakers may be mounted one above the other or side-by-side. The interlocked devices may be fixed or draw-out, three-pole or four-pole, and have different ratings.

Interlocking between two MVS frame 1 or two MVS frame 2

This function requires:

- An adaptation fixture on the right side of each device
- A set of cables with no-slip adjustments

The maximum distance between the fixing planes (vertical or horizontal) is 2000 mm.

Interlocking between three MVS frame 2

This function requires:

- A specific adaptation fixture for each type of interlocking, installed on the right side of each device
 - Two or three sets of cables with no-slip adjustments
 - The use of a mechanical operation counter CDM is compulsory
- The maximum distance between the fixing planes (vertical or horizontal) is 1000 mm.

Installation

The adaptation fixtures, sets of cables and circuit breakers or switch-disconnectors are supplied separately, ready for assembly by the customer.

Installation conditions for cable interlocking systems:

- Cable length: 2.5 m
- Radius of curvature: 100 mm
- Maximum number of curves: 3

Possible combinations of "Normal" and "Replacement" source circuit breakers

"Normal N"	"Replacement" R
MVS06 to MVS40	MVS Frame 1 or Frame 2
Ratings 630...4000A	■

Possible combinations of three device

MVS08 to MVS40	MVS Frame 2
Ratings 800...4000A	■

Electrical interlocking is used with a mechanical interlocking system.

Moreover, the relays controlling the closing order to the “S1” and “S2” circuit breakers must be mechanically and/or electrically interlocked to prevent them from giving simultaneous closing commands.

Electrical interlocking is carried out by an electrical control device.

For EasyPact & Masterpact, this function can be implemented in one of two ways:

- using the IVE unit
- by an electrician based on the diagrams in accordance with the chapter “Electric diagrams” of this catalogue.

Characteristics of the IVE unit

- External connection terminal block:
 - inputs: circuit breaker control signals
 - outputs: status of the SDE contacts on the “S1” and “S2” source circuit breakers.
- 2 connectors for the two “S1” and “S2” source circuit breakers:
 - inputs:
 - status of the OF contacts on each circuit breaker (ON or OFF)
 - status of the SDE contacts on the “S1” and “S2” source circuit breakers
 - outputs: power supply for operating mechanisms.
- Control voltage:
 - 24 to 250 V DC
 - 48 to 415 V 50/60 Hz - 440 V 60 Hz.

The IVE unit control voltage must be same as that of the circuit breaker operating mechanisms.



IVE unit.

Necessary equipment

For MVS, each circuit breaker must be equipped with:

- a remote-operation system made up of:
 - MCH gear motor
 - MX or MN opening release
 - XF closing release
 - PF “ready to close” contact
 - CDM mechanical operation counter
- an available OF contact
- one to three CE connected-position contacts (carriage switches) on drawout circuit breakers (depending on the installation).

Controller selection

By combining a remote-operated source-changeover system with an integrated BA or UA automatic controller, it is possible to automatically control source transfer according to user-selected sequences.

These controllers can be used on source-changeover systems comprising 2 circuit breakers. For source-changeover systems comprising 3 circuit breakers, the automatic control diagram must be prepared by the installer as a complement to diagrams provided in the “electrical diagrams” section of this catalogue.

DB403809 eps



BA controller.

DB403810 eps



UA controller.

Controller	BA	UA					
Compatible circuit breakers	All Masterpact & EasyPact circuit breakers						
4-position switch							
Automatic operation	■	■					
Forced operation on “Normal” source	■	■					
Forced operation on “Replacement” source	■	■					
Stop (both “Normal” and “Replacement” sources off)	■	■					
Automatic operation							
Monitoring of the “Normal” source and automatic transfer	■	■					
Generator set startup control		■					
Delayed shutdown (adjustable) of generator set		■					
Load shedding and reconnection of non-priority circuits		■					
Transfer to the “Replacement” source if one of the phases of the “Normal” phase is absent		■					
Test							
By opening the P25M circuit breaker supplying the controller	■						
By pressing the test button on the front of the controller		■					
Indications							
Circuit breaker status indication on the front of the controller: on, off, fault trip	■	■					
Automatic mode indicating contact	■	■					
Other functions							
Selection of type of “Normal” source (single-phase or three-phase) ⁽¹⁾		■					
Voluntary transfer to “Replacement” source (e.g. energy management commands)	■	■					
During peak-tariff periods (energy management commands) forced operation on “Normal” source if “Replacement” source not operational		■					
Additional contact (not part of controller). Transfer to “Replacement” source only if contact is closed. (e.g. used to test the frequency of UR).	■	■					
Setting of maximum startup time for the replacement source		■					
Options							
Communication option							
Power supply							
Control voltages ⁽²⁾	110 V	■	■				
	220 to 240 V 50/60 Hz	■	■				
	380 to 415 V 50/60 Hz and 440 V 60 Hz	■	■				
Operating thresholds							
Undervoltage	0.35 Un ≤ voltage ≤ 0.7 Un	■	■				
Phase failure	0.5 Un ≤ voltage ≤ 0.7 Un		■				
Voltage presence	voltage ≥ 0.85 Un	■	■				
IP degree of protection (EN 60529) and IK degree of protection against external mechanical impacts (EN 50102)							
Front	IP40	■	■				
Side	IP30	■	■				
Connectors	IP20	■	■				
Front	IK07	■	■				
Characteristics of output contacts (dry, volt-free contacts)							
Rated thermal current (A)	8						
Minimum load	10 mA at 12 V						
Output contacts:							
Position of the Auto/Stop switch		■	■				
Load shedding and reconnection order			■				
Generator set start order			■				
Utilisation category (IEC 947-5-1)	AC	DC					
	AC12	AC13	AC14	AC15	DC12	DC13	
Operational current (A)	24 V	8	7	5	5	8	2
	48 V	8	7	5	5	2	-
	110 V	8	6	4	4	0.6	-
	220/240 V	8	6	4	3	-	-
	250 V	-	-	-	-	0.4	-
	380/415 V	5	-	-	-	-	-
	440 V	4	-	-	-	-	-
	660/690 V	-	-	-	-	-	-

⁽¹⁾ For example, 220 V single-phase or 220 V three-phase.

⁽²⁾ The controller is powered by the ACP control plate. The same voltage must be used for the ACP plate, the IVE unit and the circuit-breaker operating mechanisms. If this voltage is the same as the source voltage, then the “Normal” and “Replacement” sources can be used directly for the power supply. If not, an isolation transformer must be used.

PB104740

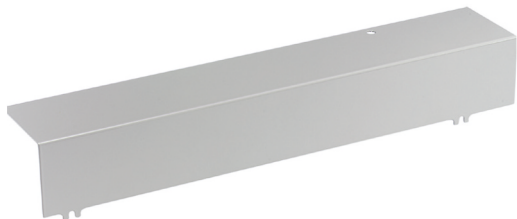

Auxiliary terminal shield CB

Optional equipment mounted on the chassis, the shield prevents access to the terminal block of the electrical auxiliaries.

PB10432A32

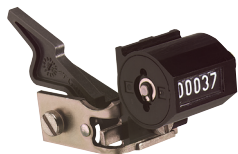

Operation counter CDM

The operation counter sums the number of operating cycles and is visible on the front panel. It is compatible with manual and electrical control functions. This option is compulsory for all the source-changeover systems.

DB101173

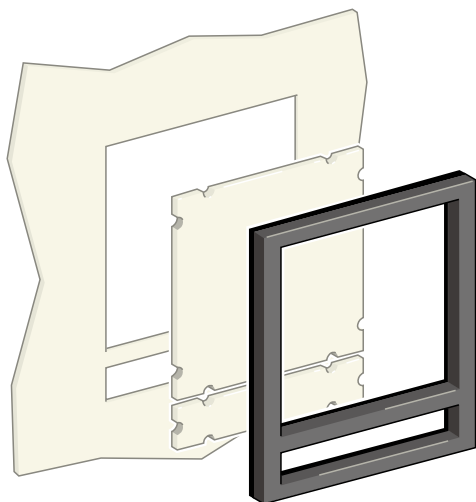

Escutcheon CDP

Standard equipment mounted on the door of the cubicle, the escutcheon increases the degree of protection to IP 40 (circuit breaker installed free standing: IP30) . It is available in fixed and draw-out versions.

Blanking plate for escutcheon OP

Used with the escutcheon, this option closes off the door cut-out of a cubicle not yet equipped with a device. It may be used with the escutcheon for both fixed and draw-out devices.

Escutcheon CDP with blanking plate.

PB100776-42

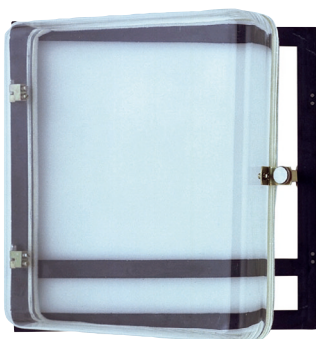

Transparent cover for escutcheon CP

Optional equipment mounted on the escutcheon, the cover is hinged and secured by a screw. It increases the degree of protection to IP54, IK10. It adapts to draw-out devices.

Transparent cover CP for escutcheon.



Installation recommendations



<i>Functions and characteristics</i>	<i>A-1</i>
Operating conditions	B-2
Installation in switchboard	B-3
Door interlock catch	B-5
Control wiring	B-6
Power connection	B-7
Recommended busbars drilling	B-9
Busbar sizing	B-11
Temperature derating	
Power dissipation	B-13
<i>Dimensions and connection</i>	<i>C-1</i>
<i>Electrical diagrams</i>	<i>D-1</i>
<i>Additional characteristics</i>	<i>E-1</i>
<i>Catalogue numbers and order form</i>	<i>F-1</i>

EasyPact MVS circuit breakers have been tested for operation in industrial atmospheres. It is recommended that the equipment be cooled or heated to the proper operating temperature and kept free of excessive vibration and dust.

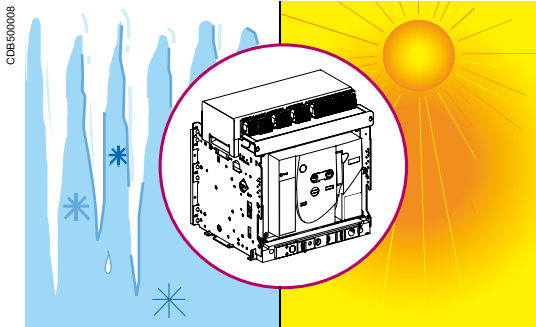

Ambient temperature

EasyPact MVS devices can operate under the following temperature conditions:

- The electrical and mechanical characteristics are stipulated for an ambient temperature of -5°C to $+60^{\circ}\text{C}$

- Circuit-breaker closing is guaranteed down to -35°C

Storage conditions are as follows:

- -40 to $+85^{\circ}\text{C}$ for a EasyPact MVS device without its control unit
- -25°C to $+85^{\circ}\text{C}$ for the control unit

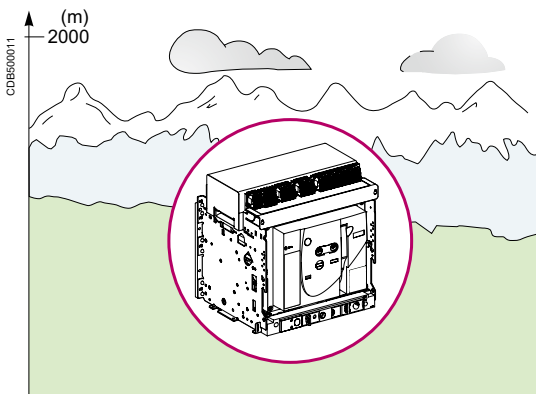

Altitude

At altitudes higher than 2000 metres, the modifications in the ambient air (electrical resistance, cooling capacity) lower the following characteristics as follows:

Altitude (m)	2000	3000
Impulse withstand voltage u_{imp} (kV)	12	11
Rated insulation voltage (U_i)	1000	900
Maximum rated operational voltage 50/60 Hz U_e (V)	690	590
Rated current 40°C	$1 \times I_n$	$0.99 \times I_n$

Intermediate values may be obtained by interpolation.

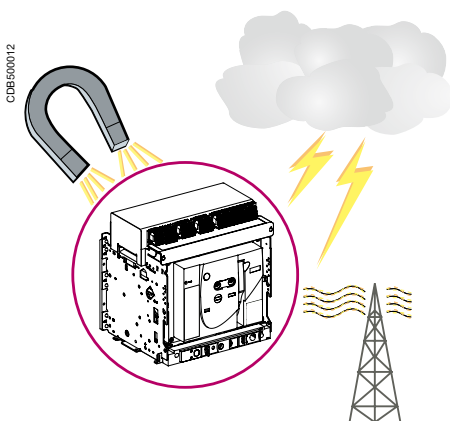

Electromagnetic disturbances

EasyPact MVS devices are protected against:

- Overvoltages caused by devices that generate electromagnetic disturbances
- Overvoltages caused by atmospheric disturbances or by a distribution-system outage (e.g. failure of a lighting system)
- Devices emitting radio waves (radios, walkie-talkies, radar, etc.)
- Electrostatic discharges produced by users

EasyPact MVS devices have successfully passed the electromagnetic-compatibility tests (EMC) defined by the following international standards:

- IEC 60947-2, appendix F

The above tests guarantee that:

- No nuisance tripping occurs
- Tripping times are respected

Installation in switchboard

Possible positions

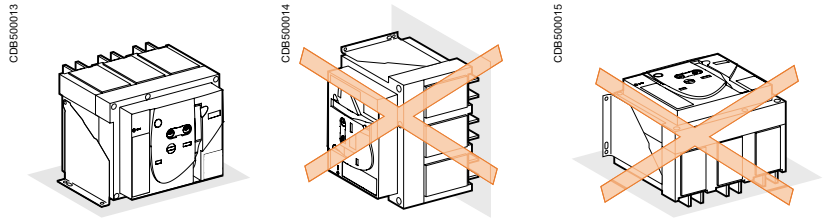

Power supply

EasyPact MVS devices can be supplied either from the top or from the bottom without reduction in performance, in order to facilitate connection when installed in a switchboard.

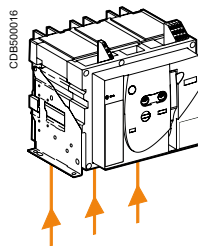

Mounting the circuit-breaker

It is important to distribute the weight of the device uniformly over a rigid mounting surface such as rails or a base plate.

This mounting plane should be perfectly flat (tolerance on support flatness: 2 mm). This eliminates any risk of deformation which could interfere with correct operation of the circuit breaker.

EasyPact devices can also be mounted on a vertical plane using the special brackets.

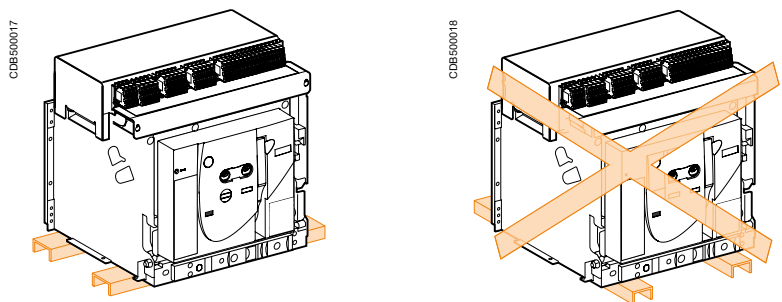

Mounting on rails.

Partitions

Sufficient openings must be provided in partitions to ensure good air circulation around the circuit breaker; Any partition between upstream and downstream connections of the device must be made of nonmagnetic material.

For high currents, of 2500 A and upwards, the metal supports or barriers in the immediate vicinity of a conductor must be made of non-magnetic material **A**. Metal barriers through which a conductor passes must not form a magnetic loop.

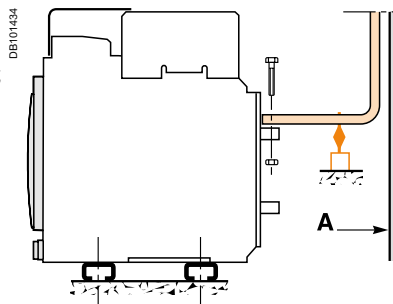

A : Non magnetic material.

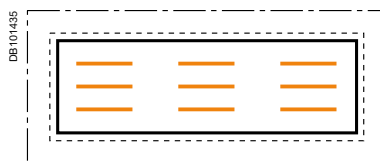

Busbars

The mechanical connection must exclude the possibility of formation of a magnetic loop around a conductor.

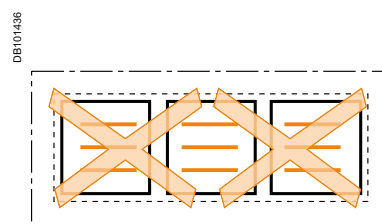
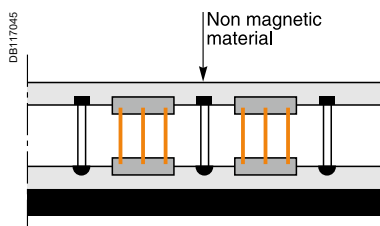

Interphase barrier

If the insulation distance between phases is not sufficient (≤ 14 mm), it is advised to install phase barriers (taking into account the safety clearances).

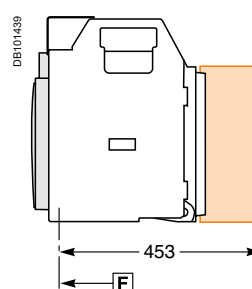
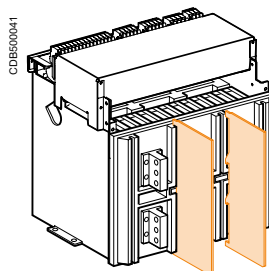

Door interlock VPEC

Mounted on the right or left-hand side of the chassis, this device inhibits opening of the cubicle door when the circuit breaker is in "connected" or "test" position.

If the breaker is put in the "connected" position with the door open, the door may be closed without having to disconnect the circuit breaker.

Dimensions (mm)

Type	(1)	(2)
MVS frame 1 (3P)	135	168
MVS frame 1 (4P)	205	168
MVS frame 2 (3P)	215	215
MVS frame 2 (4P)	330	215

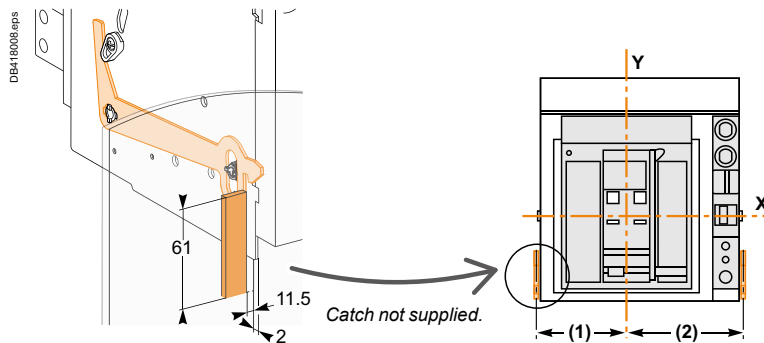

MVS frame 1

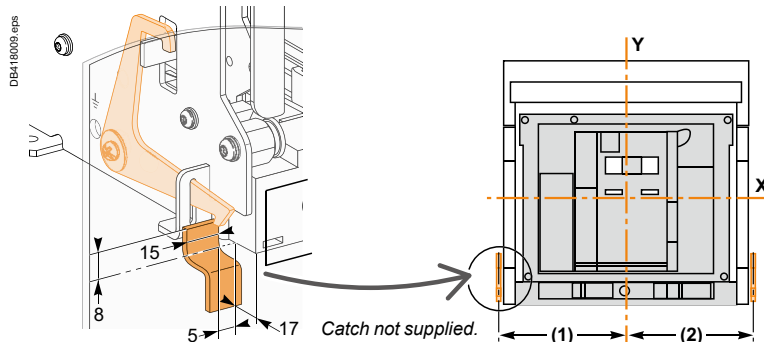

MVS frame 2

Breaker in "connected" or "test" position

Door cannot be opened

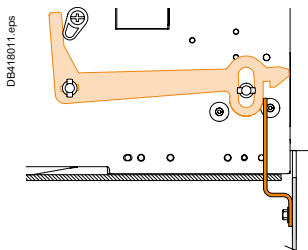

MVS frame 1

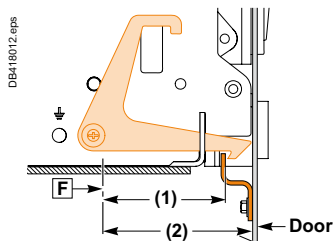

MVS frame 2.

Breaker in "disconnected" position

Door can be opened

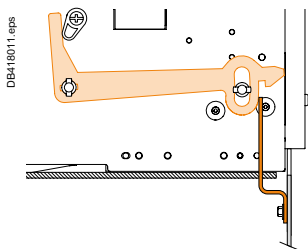

MVS frame 1.

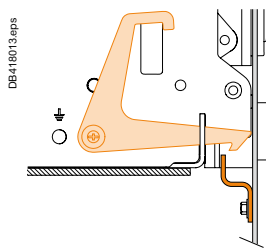

MVS frame 2.

Dimensions (mm)

Type	(1)	(2)
MVS frame 1	5	23
MVS frame 2	87	103

Wiring of voltage releases

During pick-up, the power consumed is approximately 150 to 200 VA. For low control voltages (12, 24, 48 V), maximum cable lengths are imposed by the voltage and the cross-sectional area of cables.

Recommended maximum cable lengths (meter).

		12 V		24 V		48 V	
		2,5 mm ²	1,5 mm ²	2,5 mm ²	1,5 mm ²	2,5 mm ²	1,5 mm ²
MN	U source 100 %	–	–	58	35	280	165
	U source 85 %	–	–	16	10	75	45
MX-XF	U source 100 %	21	12	115	70	550	330
	U source 85 %	10	6	75	44	350	210

Note: The indicated length is that of each of the two wires.

24 V DC power-supply module

External 24 V DC power-supply module (F1-, F2+)

- Do not connect the positive terminal (F2+) to earth
- The negative terminal (F1-) can be connected to earth
- A number of trip units can be connected to the same 24 V DC power supply (the consumption of a trip unit is approximately 100 mA)
- Do not connect any devices other than a trip unit
- The maximum length for each conductor is ten metres. For greater distances, it is advised to twist the supply wires together
- The 24 V DC supply wires must cross the power cables perpendicularly. If this is difficult, it is advised to twist the supply wires together
- The technical characteristics of the external 24 V DC power-supply module are indicated on [page A-14](#).

Note: Wiring of ZSI: it is recommended to use twisted shielded cable. The shield must be connected to earth at both ends.

Power connection

Cables connections

If cables are used for the power connections, make sure that they do not apply excessive mechanical forces to the circuit breaker terminals.

For this, make the connections as follows:

- Extend the circuit breaker terminals using short bars designed and installed according to the recommendations for bar-type power connections:
- For a single cable, use solution **B** opposite
- For multiple cables, use solution **C** opposite
- In all cases, follow the general rules for connections to busbars:
- Position the cable lugs before inserting the bolts
- The cables should firmly secured to the framework

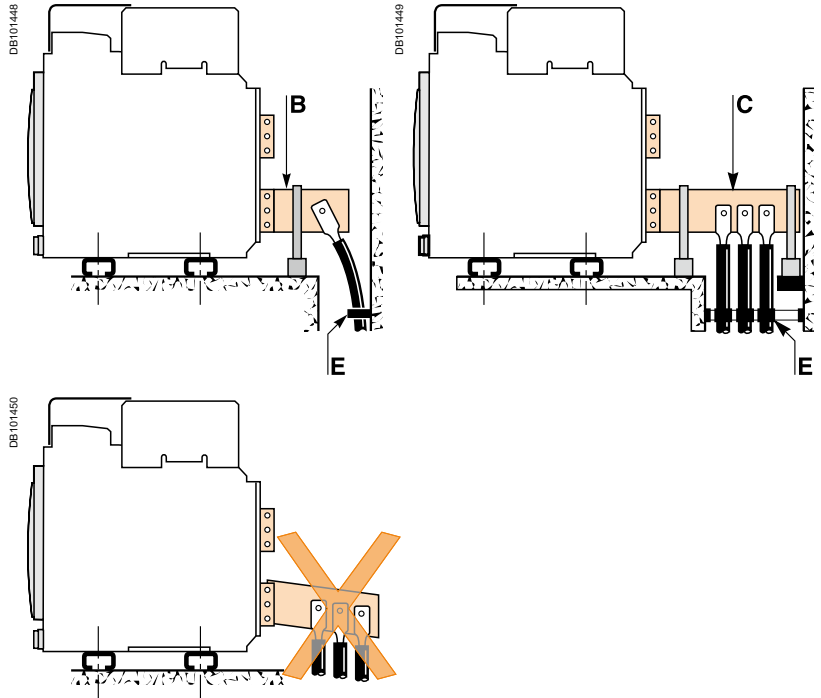

Busbars connections

The busbars should be suitably adjusted to ensure that the connection points are positioned on the terminals before the bolts are inserted **B**. The connections are held by the support which is solidly fixed to the framework of the switchboard, such that the circuit breaker terminals do not have to support its weight **C**. (This support should be placed close to the terminals).

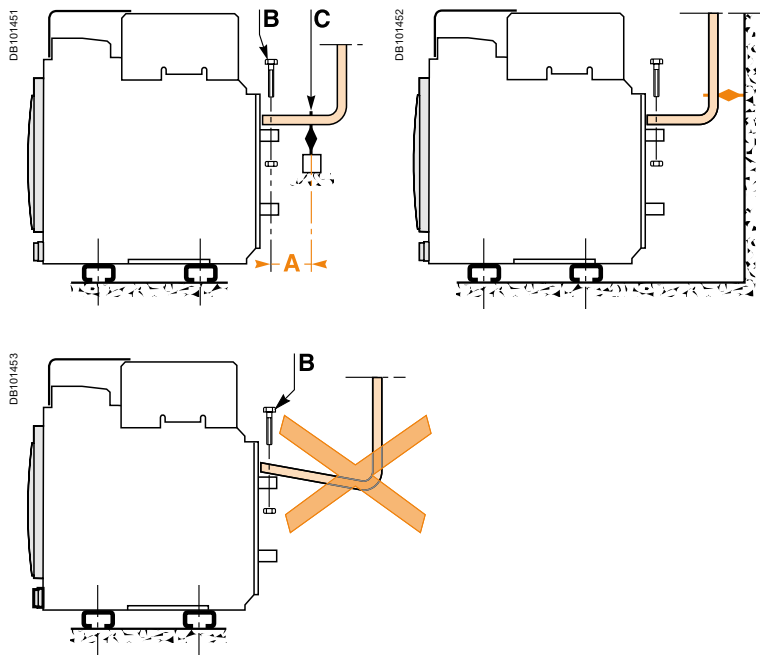

Electrodynamic stresses

The first busbar support or spacer shall be situated within a maximum distance from

the connection point of the breaker (see table below). This distance must be respected so that the connection can withstand the electrodynamic stresses between phases in the event of a short circuit.

Maximum distance A between busbar to circuit breaker connection and the first busbar support or spacer with respect to the value of the prospective short-circuit current.

Isc (kA)	30	50	65
Distance A (mm)	350	300	250

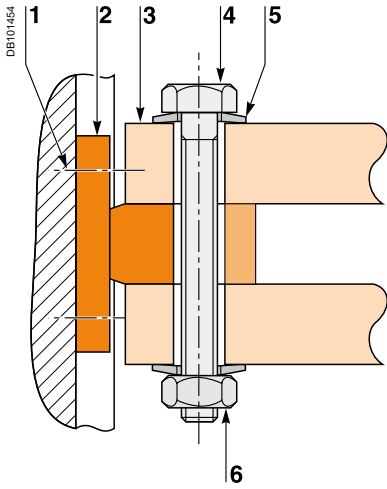

- 1 Terminal screw factory-tightened to 16 Nm.
- 2 Breaker terminal.
- 3 Busbar.
- 4 Bolt.
- 5 Washer.
- 6 Nut.

Clamping

Correct clamping of busbars depends amongst other things, on the tightening torques used for the nuts and bolts. Over-tightening may have the same consequences as under-tightening. For connecting busbars (Cu ETP-NFA51-100) to the circuit breaker, the tightening torques to be used are shown in the table below. These values are for use with copper busbars and steel nuts and bolts, class 8.8. The same torques can be used with AGS-T52 quality aluminium bars (French standard NFA 02-104 or American National Standard H-35-1).

Examples

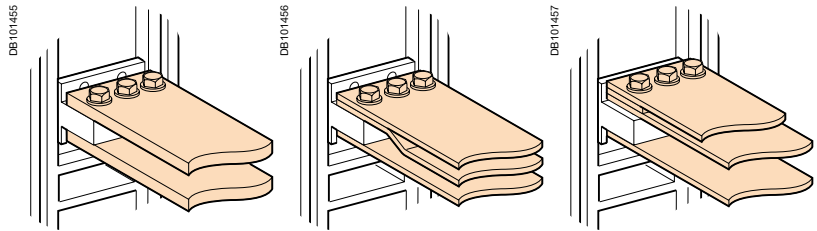

Tightening torques

Ø (mm) Nominal	Ø (mm) Drilling	Tightening torques (Nm) with grower or flat washers	Tightening torques (Nm) with contact or corrugatec washers
10	11	37.5	50

Busbar drilling

Examples

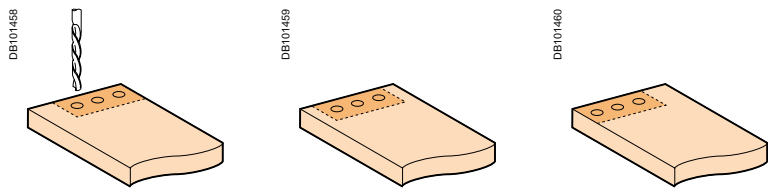

Isolation distance

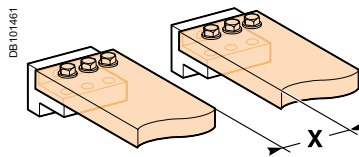

Dimensions (mm)

U _i	X min
600 V	8 mm
1000 V	14 mm

Busbar bending

When bending busbars maintain the radius indicated below (a smaller radius would cause cracks).

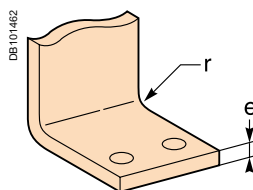

Dimensions (mm)

e	Radius of curvature r	
	Min	Recommended
5	5	7.5
10	15	18 to 20

Rear connection

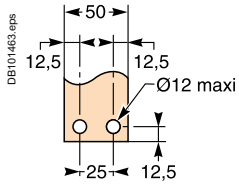

Rear connection with spreaders

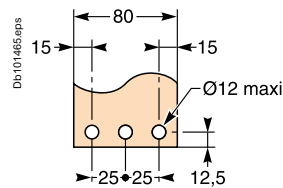
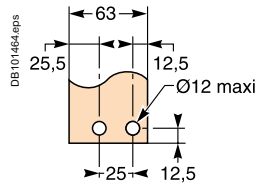
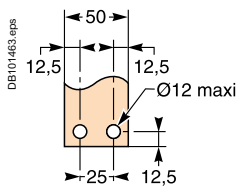

Middle left or middle right spreader for 4P

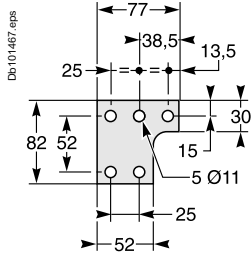
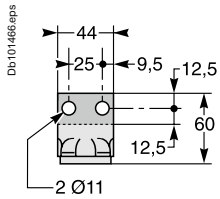

Middle spreader for 3P

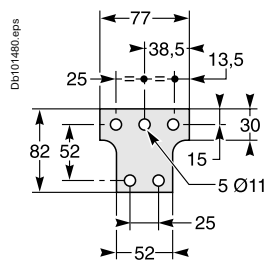

Left or right spreader for 4P

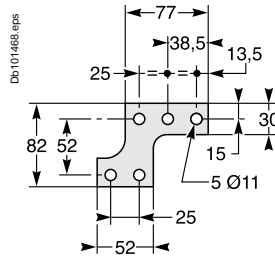

Left or right spreader for 3P

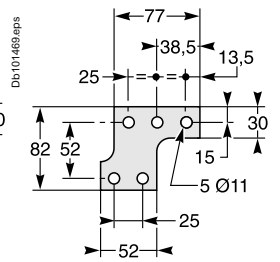

Vertical rear connection

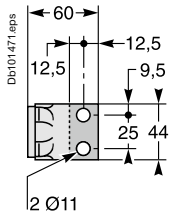

Recommended busbars drilling

EasyPact MVS Frame 2: 800-4000A

Horizontal rear connection MVS08 to MVS32

MVS40

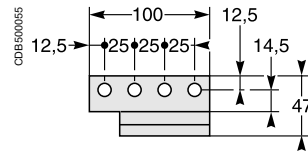
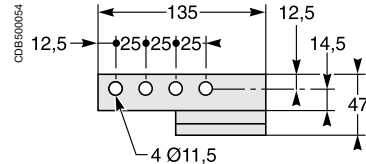
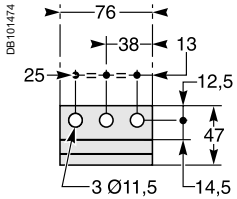
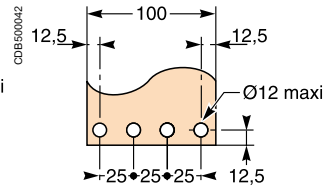
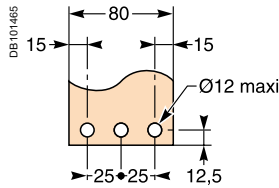
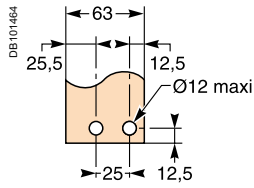
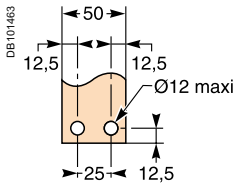

Vertical rear connection MVS08 to MVS32

MVS40

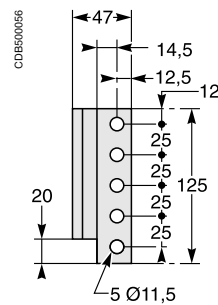
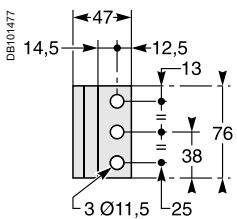
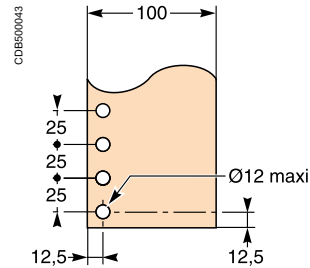
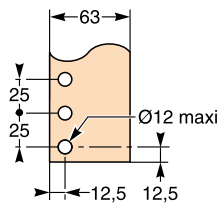
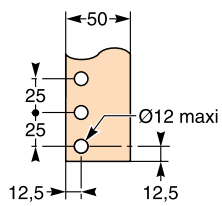
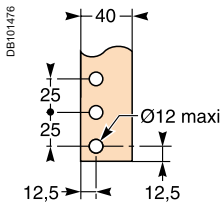

Basis of tables:

- Maximum permissible busbars temperature: 100 °C
- T_i : temperature around the circuit breaker and its connection
- Busbar material is unpainted Copper / Aluminium

Rear horizontal connection

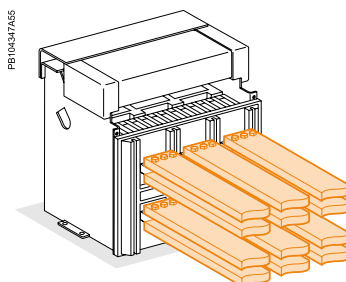

Unpainted Copper (Rear Horizontal connection)

EasyPact	Maximum service current (A)	Ti: 40°C		Ti: 50°C	
		No. of 5mm thick bars	No. of 10mm thick bars	No. of 5mm thick bars	No. of 10mm thick bars
MVS06	630	2b.40x5	1b. 40x10	2b.40x5	1b. 40x10
MVS08	800	2b.50x5	1b. 50x10	2b.50x5	1b. 50x10
MVS10	1000	3b.50x5	1b. 63x10	3b.50x5	2b. 50x10
MVS12	1250	3b.50x5 2b.80x5	2b. 40x10	3b.50x5 2b 80 x5	2b. 50x10
MVS16	1600	3b.80x5	2b. 63x10	3b.80x5	2b. 63x10
MVS20	2000	3b.100x5	2b. 63x10	3b.100x5	2b. 80x10
MVS25	2500	4b.100x5	2b. 80x10	4b.100x5	2b. 100x10
MVS32	3200	6b.100x5	3b. 100x10	8b.100x5	3b. 100x10
MVS40	4000	-	5b. 100x10	-	5b. 100x10

Example

Conditions:

- Drawout version
- Horizontal busbars
- T_i : 50°C
- Service current: 1600A

Solution:

For $T_i = 50^\circ\text{C}$, use an MVS16 which can be connected with 2 bars-63x10mm copper (or) 3 bars-80x10mm Aluminium.

Unpainted Aluminum

EasyPact	Maximum service current (A)	Busbar Orientation	Ti: 50°C No. of 10mm thick bars
MVS06	630	Horizontal	2b. 40 X10
MVS08	800	Horizontal	2b. 40 X10
MVS10	1000	Horizontal	2b. 50 X10
MVS12	1250	Horizontal	2b. 80 X10
MVS16	1600	Horizontal	3b. 80 X10

Note: The values indicated in these tables have been extrapolated from test data and theoretical calculations. These tables are only intended as a guide and cannot replace industrial experience or a temperature rise test.

Busbar sizing

Basis of tables:

- Maximum permissible busbars temperature: 100 °C
- T_i : temperature around the circuit breaker and its connection
- Busbar material is unpainted Copper / Aluminium

Rear vertical connection

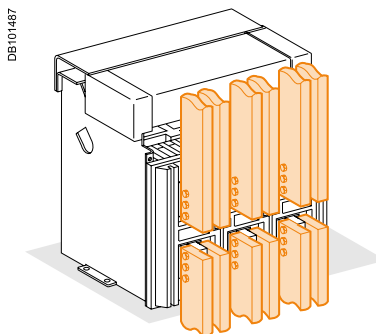

Unpainted Copper(vertical connection)					
EasyPact	Maximum service current (A)	T_i : 40°C		T_i : 50°C	
		No. of 5mm thick bars	No. of 10mm thick bars	No. of 5mm thick bars	No. of 10mm thick bars
MVS06	630	2b.40x5	1b. 40x10	2b.40x5	1b. 40x10
MVS08	800	2b.50x5	1b. 50x10	2b.50x5	1b. 50x10
MVS10	1000	2b.50x5	1b. 50x10	2b.50x5	1b. 50x10
MVS12	1250	2b.63x5	2b. 40x10	3b.50x5	2b. 40x10
MVS16	1600	3b.63x5	2b. 50x10	3b.63x5	2b. 50x10
MVS20	2000	3b.100x5	2b. 63x10	3b.100x5	2b. 63x10
MVS25	2500	4b.100x5	2b. 80x10	4b.100x5	2b. 80x10
MVS32	3200	6b.100x5	3b. 100x10	6b.100x5	3b. 100x10
MVS40	4000	-	4b. 100x10	-	4b. 100x10

Example

Conditions:

- Drawout version
- Vertical connections
- T_i : 40 °C
- Service current: 1100 A.

Solution:

For $T_i = 40$ °C use an MVS12 which can be connected with two 63 x 5 mm bars or with one 63 x 10 mm bar.

Unpainted Aluminum			
EasyPact	Maximum service current (A)	Busbar Orientation	T_i : 50°C No. of 10mm thick bars
MVS06	630	Vertical	2b. 40 X10
MVS08	800	Vertical	2b. 40 X10
MVS10	1000	Vertical	2b. 50 X10
MVS12	1250	Vertical	2b. 80 X10
MVS16	1600	Vertical	3b. 80 X10
MVS20	2000	Vertical	4b. 80 X10
MVS25	2500	Vertical	4b. 100 X10
MVS32	3200	Vertical	4b. 150 X10
MVS40	4000	Vertical	5b. 150 X10

Note: The values indicated in these tables have been extrapolated from test data and theoretical calculations. These tables are only intended as a guide and cannot replace industrial experience or a temperature rise test.

Temperature derating Power dissipation

Temperature derating

The table below indicates the maximum current rating, for each connection type, as a function of T_i around the circuit breaker and the busbars.

For T_i greater than 60°C, consult us.

T_i : temperature around the circuit breaker and its connection.

Version	Draw-out					Fixed														
	Rear horizontal					Rear vertical					Rear horizontal					Rear vertical				
Temp. T_i	40 °C	45 °C	50 °C	55 °C	60 °C	40 °C	45 °C	50 °C	55 °C	60 °C	40 °C	45 °C	50 °C	55 °C	60 °C	40 °C	45 °C	50 °C	55 °C	60 °C
MVS (50kA)																				
MVS06C	630					630					630					630				
MVS08C	800					800					800					800				
MVS10C	1000					1000					1000					1000				
MVS12C	1250					1250					1250					1250				
MVS16C	1600	1560	1520	1480	1440	1600		1560	1520		1600			1560		1600				
MVS08N	800					800					800					800				
MVS10N	1000					1000					1000					1000				
MVS12N	1250					1250					1250					1250				
MVS16N	1600					1600					1600					1600				
MVS20N	2000		1900			2000			1900		2000		1920			2000				
MVS25N	2500		2450			2500		2500			2500			2500						
MVS32N	3200		3100		3000		2900		3200		3200		3200							
MVS40N	4000		3900		3750		3650		4000		3900		3800		4000					
MVS (65kA)																				
MVS08H	800					800					800					800				
MVS10H	1000					1000					1000					1000				
MVS12H	1250					1250					1250					1250				
MVS16H	1600					1600					1600					1600				
MVS20H	2000		1900			2000			1900		2000		1920			2000				
MVS25H	2500	2450	2400	2300	2200	2500		2450	2400	2300	2500			2500		2500				
MVS32H	3200		3100		3000		2900		3200		3200		3200							
MVS40H	4000		3900		3750		3650		4000		3900		3800		4000					

Power dissipation

Total power dissipation is the value measured at I_N , 50/60 Hz, for a 3 pole or 4 pole breaker (values above the power $P = 3RI^2$). The resistance between input / output is the value measured per pole (cold state).

Type	Draw-out		Fixed	
Frame 1-50kA	Power loss (W)	Input/output resistance (μohm)	Power loss (W)	Input/output resistance (μohm)
MVS06C	55	38	30	26
MVS08C	90	38	50	26
MVS10C	150	38	80	26
MVS12C	250	36	130	26
MVS16C	460	36	220	26
Frame 2-50kA	Power loss (W)	Input/output resistance (μohm)	Power loss (W)	Input/output resistance (μohm)
MVS08N	120	36	60	19
MVS10N	180	36	100	19
MVS12N	280	36	140	19
MVS16N	460	36	200	19
MVS20N	470	30	250	13
MVS25N	600	19	260	13
MVS32N	670	13	420	8
MVS40N	900	11	650	8
Frame 2-65kA	Power loss (W)	Input/output resistance (μohm)	Power loss (W)	Input/output resistance (μohm)
MVS08H	100	30	42	13
MVS10H	150	30	70	13
MVS12H	230	30	100	13
MVS16H	390	30	170	13
MVS20H	470	30	250	13
MVS25H	600	19	260	8
MVS32H	670	13	420	8
MVS40H	900	11	650	8

Dimensions and connection



<i>Functions and characteristics</i>	A-1
<i>Installation recommendations</i>	B-1
MVS frame 1(630 to 1600A)circuit breakers	C-2
Fixed 3/4-poles device	C-2
Draw-out 3/4 poles device	C-4
MVS Frame 2(800 to 3000A) circuit breakers	C-6
Fixed 3/4-poles device	C-6
Draw-out 3/4-poles device	C-8
MVS Frame 2(4000A) circuit breakers	C-10
Fixed 3/4-poles device	C-10
Draw-out 3/4-poles device	C-12
Accessories	C-14
External modules	C-15
<i>Electrical diagrams</i>	D-1
<i>Additional characteristics</i>	E-1
<i>Catalogue numbers and order form</i>	F-1

MVS Frame 1 (630 to 1600A) circuit breakers

Fixed 3/4-poles device

Dimensions

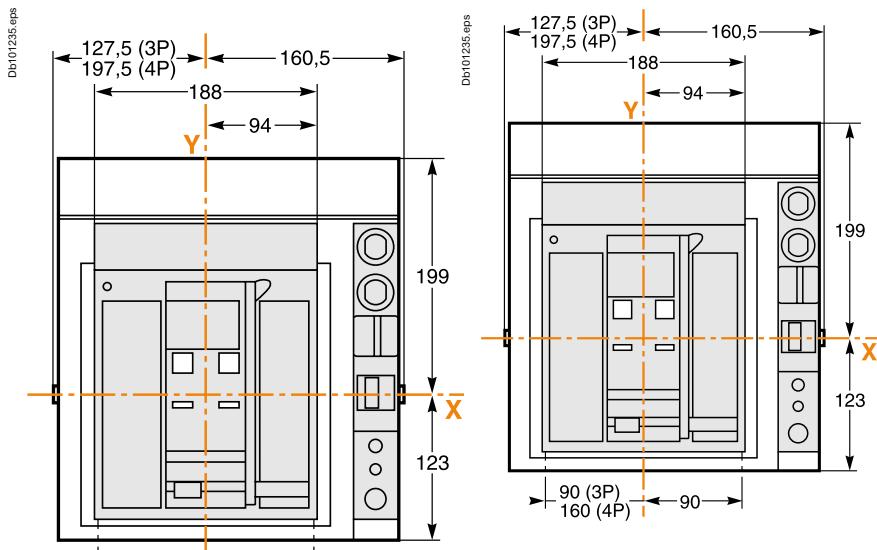

(*) Disconnected position.

Bottom mounting (on base plate or rails)

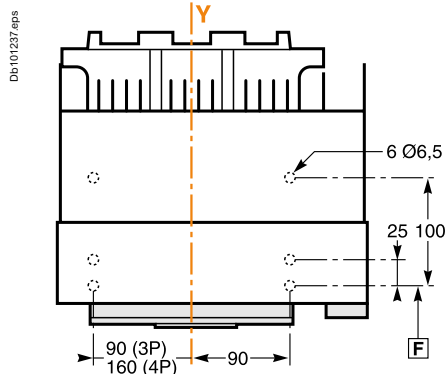
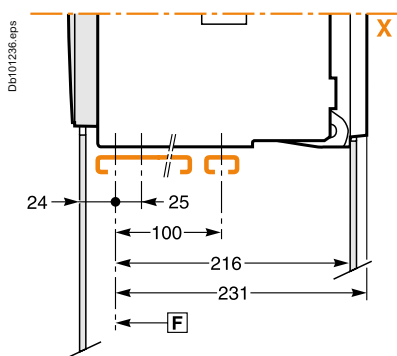

Rear mounting detail (on upright or backplate)

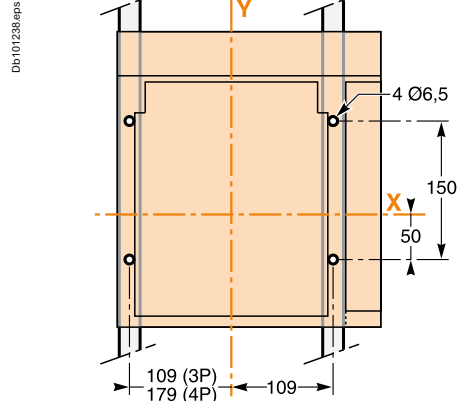

Safety clearances

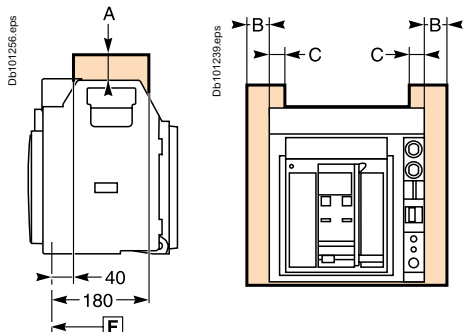

Door cutout

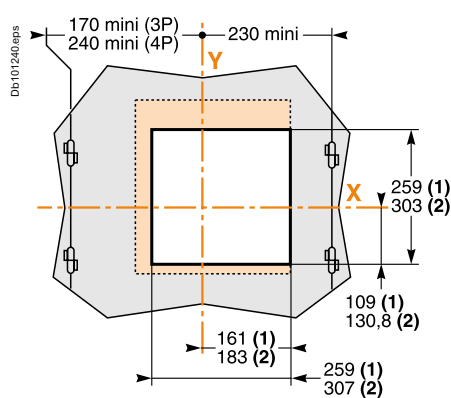

Rear panel cutout

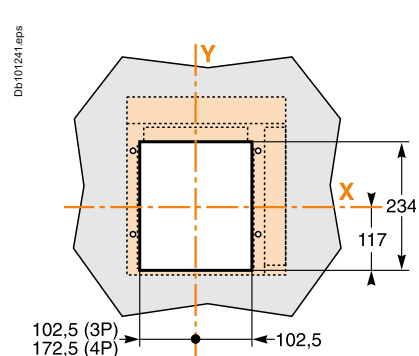

For voltages ≤ 690 V

	Parts		
	Insulated	Metal	Energised
A	0	0	30
B	10	10	60
C	0	0	30

F: datum.

(1) Without escutcheon.

(2) With escutcheon.

Note: X and Y are the symmetry planes for a 3-pole device.

MVS Frame 1 (630 to 1600A) circuit breakers

Fixed 3/4-poles device

Connections

Horizontal rear connection

Detail

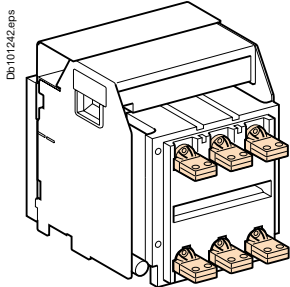

Db101242.eps

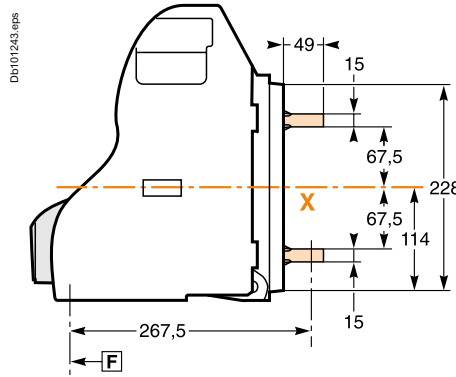

Db101243.eps

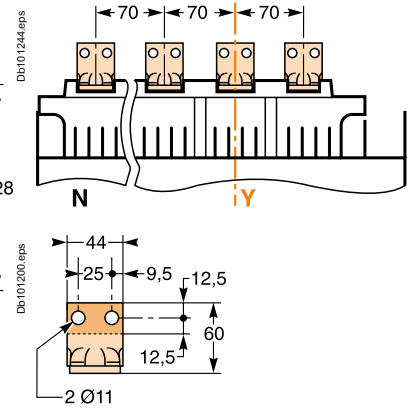

Db101244.eps

Db101200.eps

Vertical rear connection

Detail

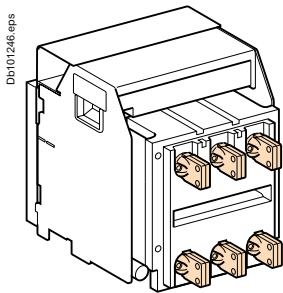

Db101246.eps

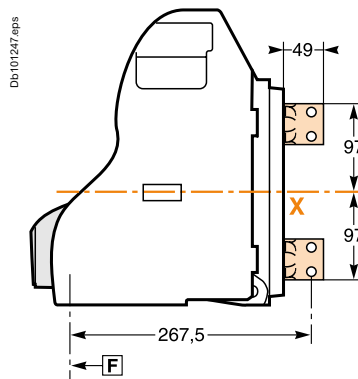

Db101247.eps

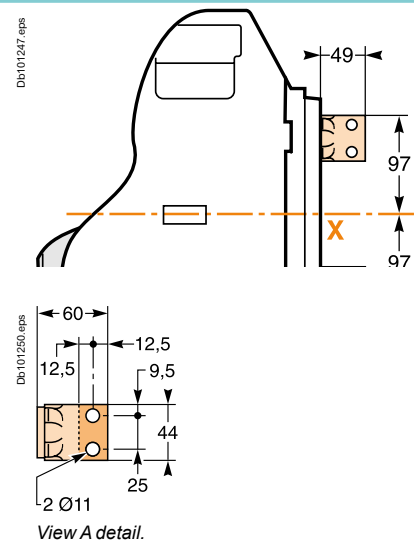

Db101247.eps

Db101250.eps

View A detail.

Note: recommended connection screws: **M10** class 8.8.
Tightening torque: **50 Nm** with contact washer.

MVS Frame 1 (630 to 1600A) circuit breakers

Draw-out 3/4-poles device

Dimensions

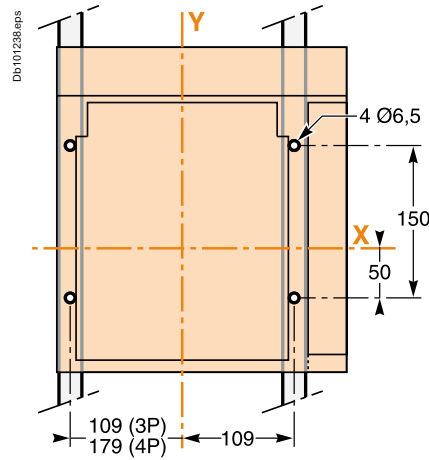
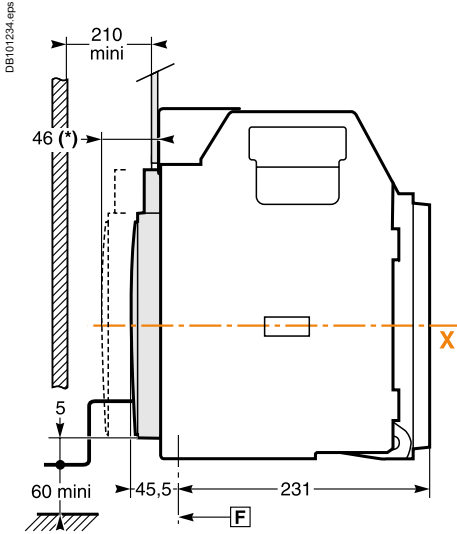

(*) Disconnected position.

Bottom mounting (on base plate or rails)

Rear mounting detail (on upright or backplate)

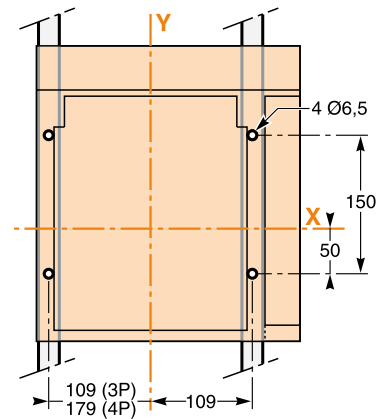
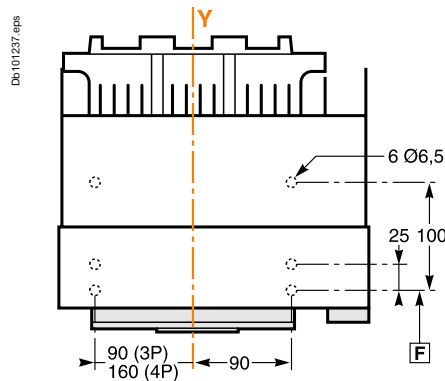
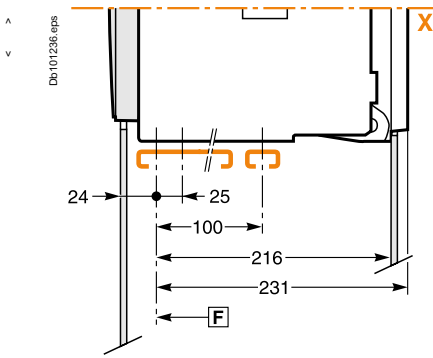

Safety clearances

Door cutout

Rear panel cutout

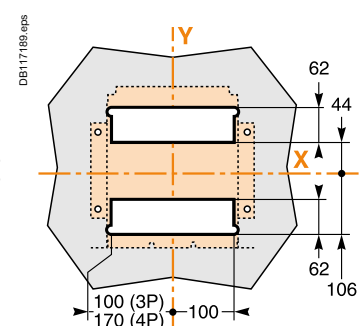
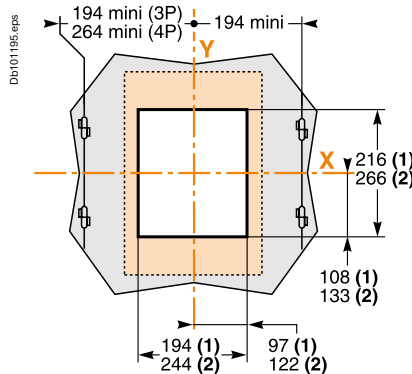
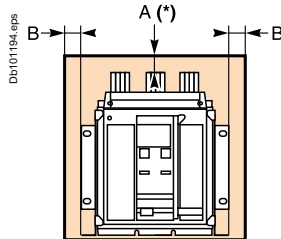
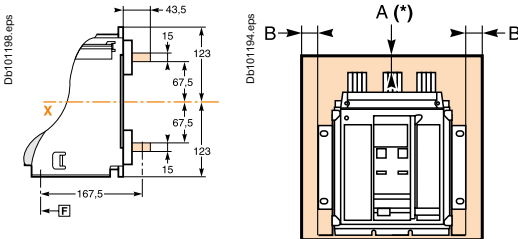

For voltages < 690 V

	Parts		
	Insulated	Metal	Energised
A	0	0	100
B	0	0	60
C	0	0	30

F : datum.

(1) Without escutcheon.

(2) With escutcheon.

Note: X and Y are the symmetry planes for a 3-pole device.

A(*) An overhead clearance of 50 mm is required to remove the arc chutes.
An overhead clearance of 20 mm is required to remove the terminal block.

MVS Frame 1 (630 to 1600A) circuit breakers

Draw-out 3/4-poles device

Connections

Horizontal rear connection

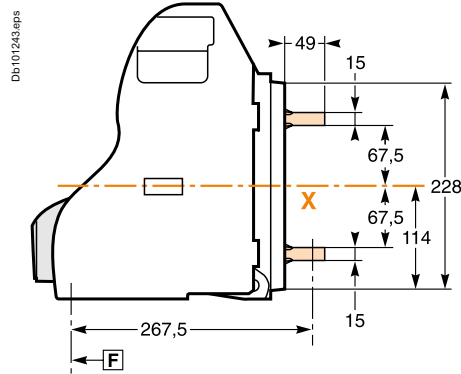
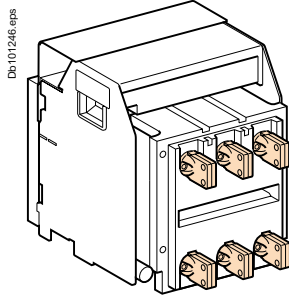

Detail

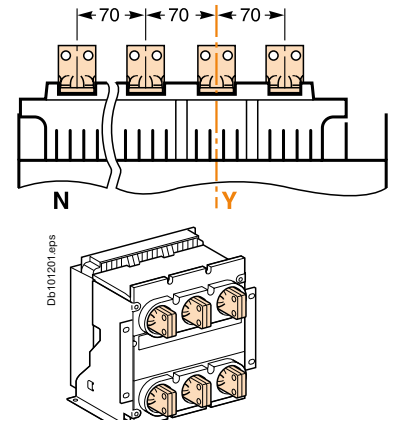

Vertical rear connection

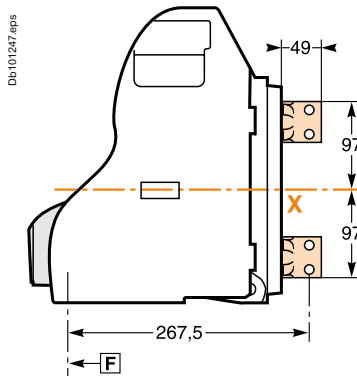
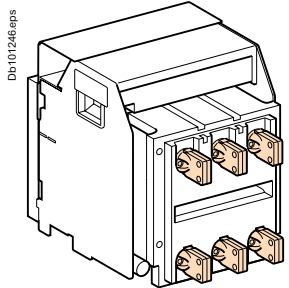

Detail

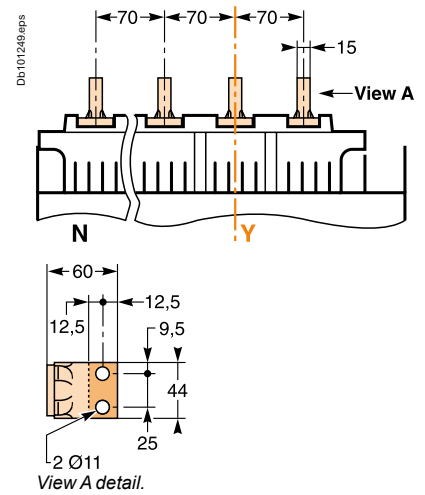

Note: recommended connection screws: **M10** class 8.8.
Tightening torque: **50 Nm** with contact washer.

MVS Frame 2(800 to 3200A) Circuit Breakers

Fixed 3/4-poles device

Dimensions

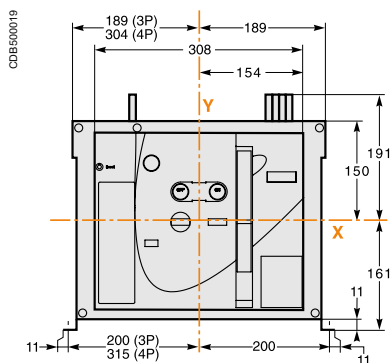
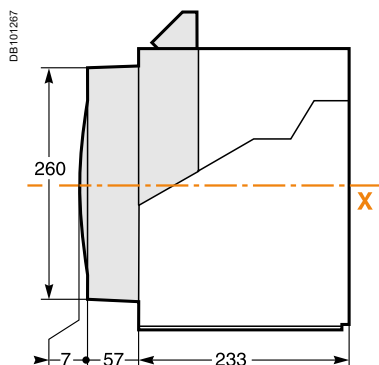

Mounting on base plate or rails

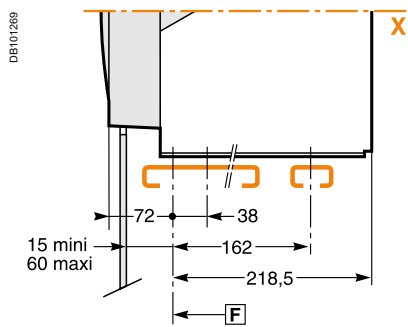

Mounting detail

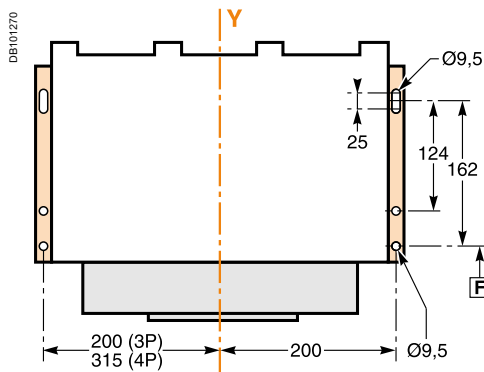

Safety clearances

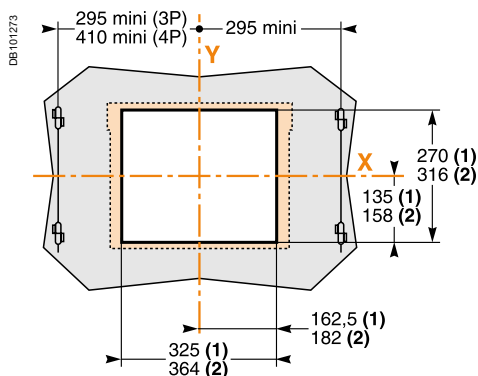
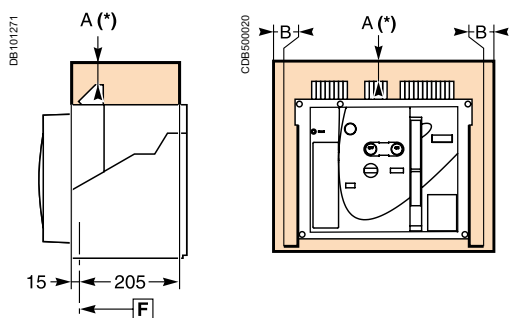

	Insulated parts	Metal parts	Energised parts
A	0	0	100
B	0	0	60

F: Datum.

(1) Without escutcheon.

(2) With escutcheon.

Note: X and Y are the symmetry planes for a 3-pole device.

A(*) An overhead clearance of 50 mm is required to remove the arc chutes.
An overhead clearance of 20 mm is required to remove the terminal block.

MVS Frame 2(800 to 3200A) Circuit Breakers

Fixed 3/4-poles device

Connections

Horizontal rear connection

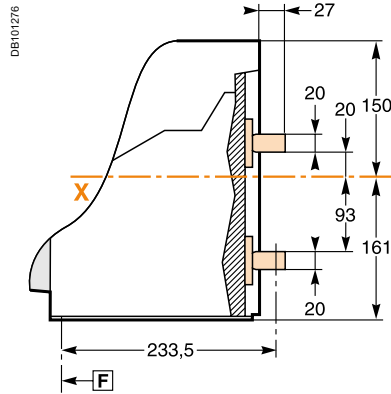
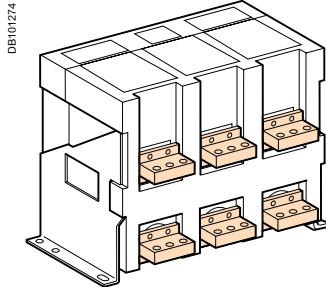

Detail

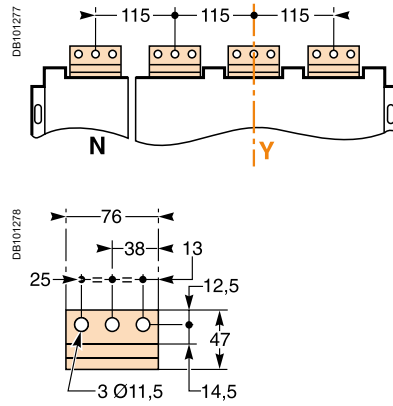

Vertical rear connection

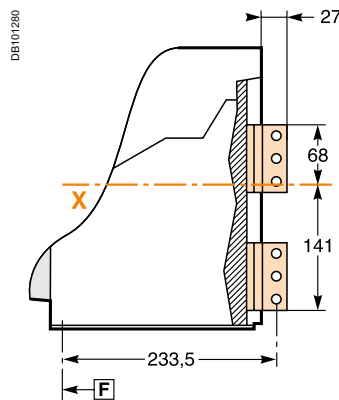
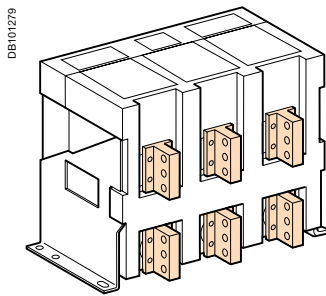

Detail

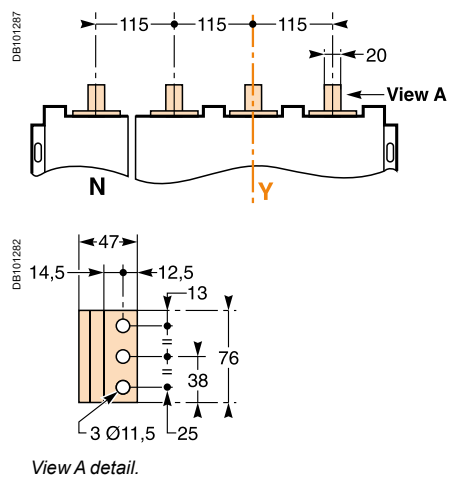

Note: Recommended connection screws: **M10** class 8.8.
Tightening torque: **50 Nm** with contact washer.

MVS Frame 2(800 to 3200A) circuit breakers

Draw-out 3/4-poles device

Dimensions

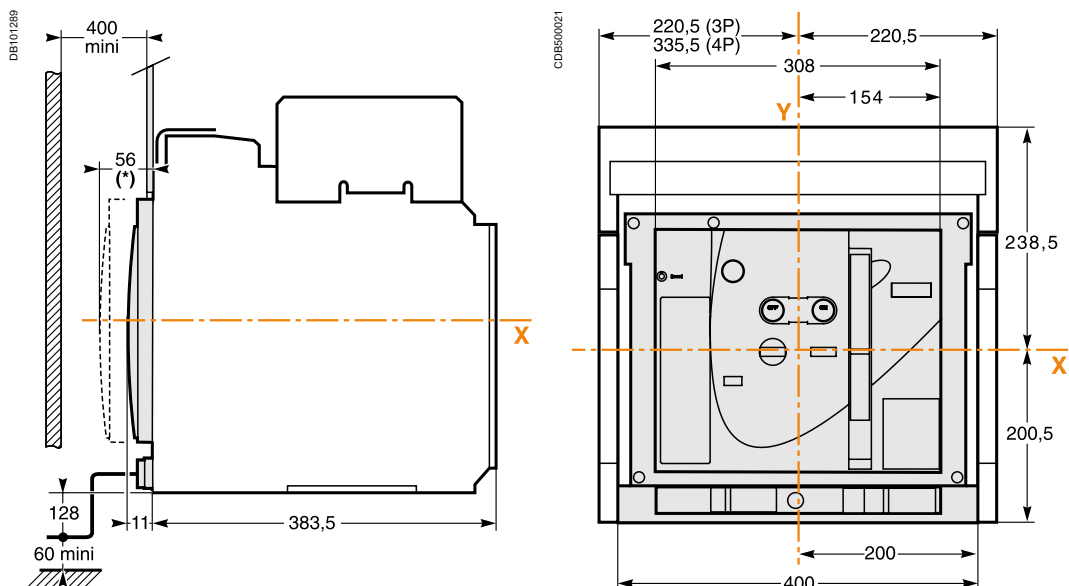

(*) Disconnected position.

Mounting on base plate or rails

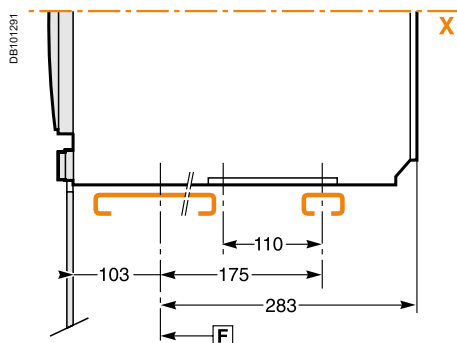

Mounting detail

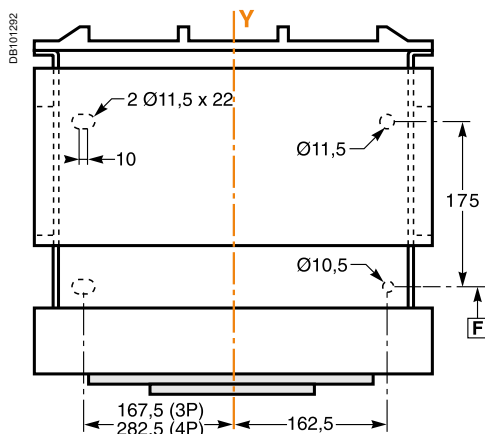

Safety clearances

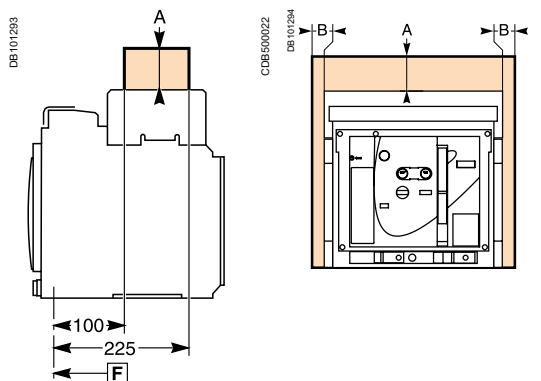

Door cutout

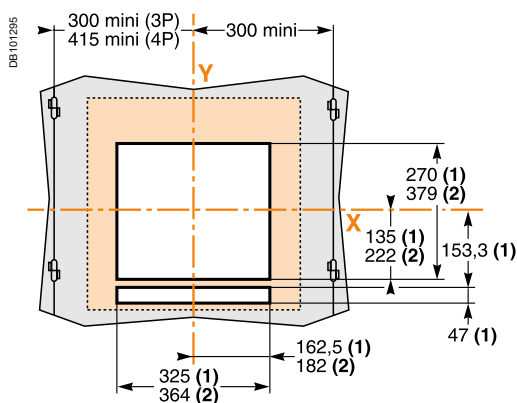

	Insulated parts	Metal parts	Energised parts
A	0	0	60
B	0	0	60

F : Datum.

(1) Without escutcheon.

(2) With escutcheon.

Note: X and Y are the symmetry planes for a 3-pole device.

MVS Frame 2(800 to 3200A) circuit breakers

Draw-out 3/4-poles device

Connections

Horizontal rear connection

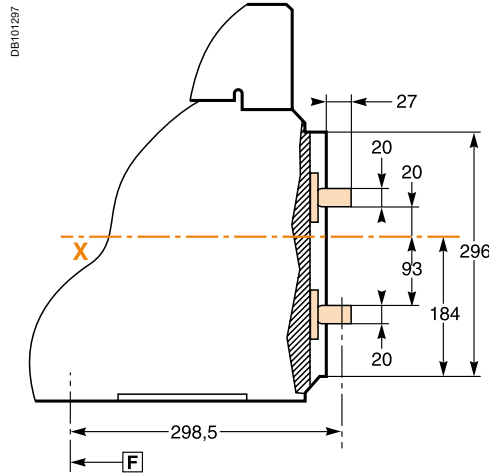
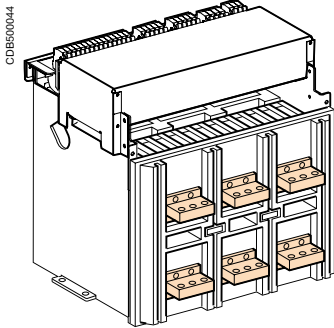

Detail

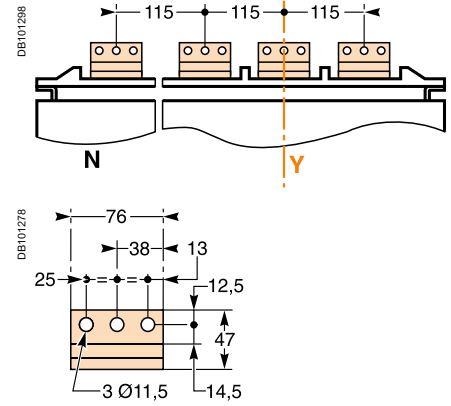

Vertical rear connection

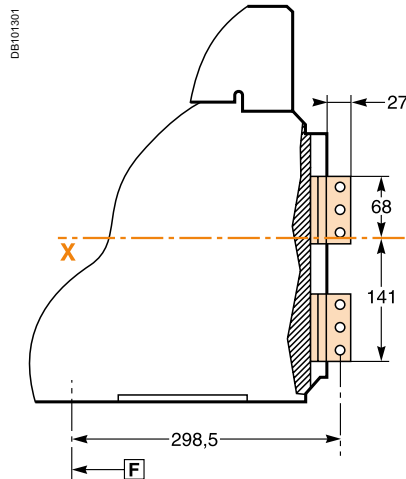
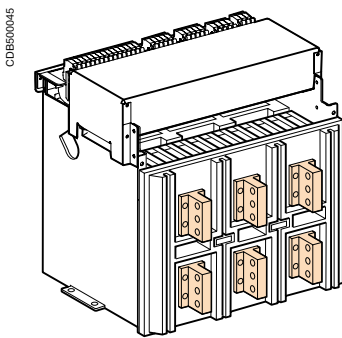

Detail

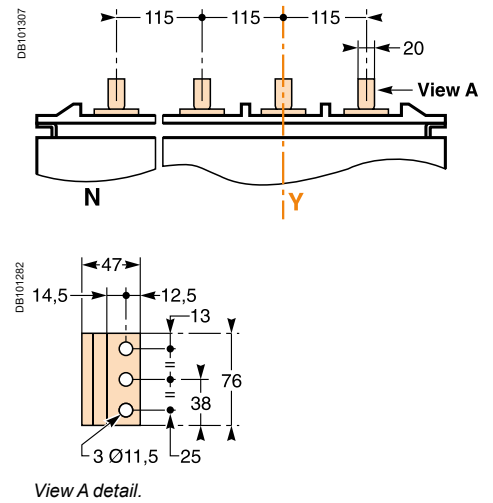

Note: Recommended connection screws: **M10** class 8.8.
Tightening torque: **50 Nm** with contact washer.

MVS Frame 2(4000A) circuit breakers

Fixed 3/4-poles device

Dimensions

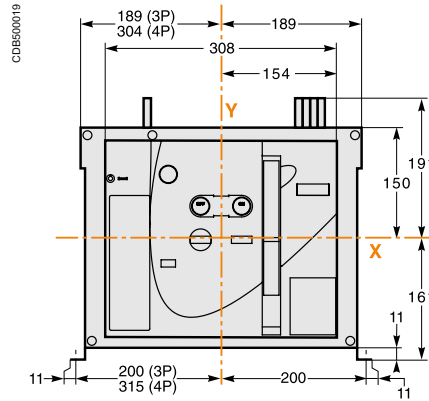
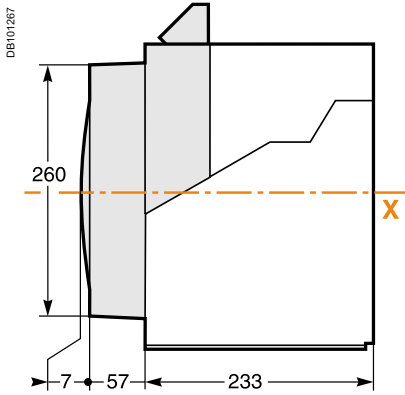

Mounting on base plate or rails

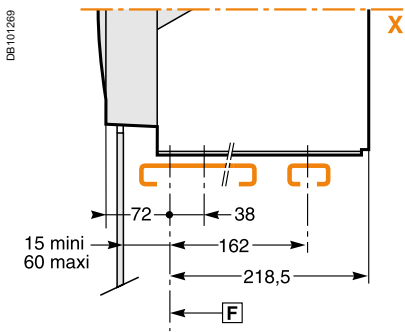

Mounting detail

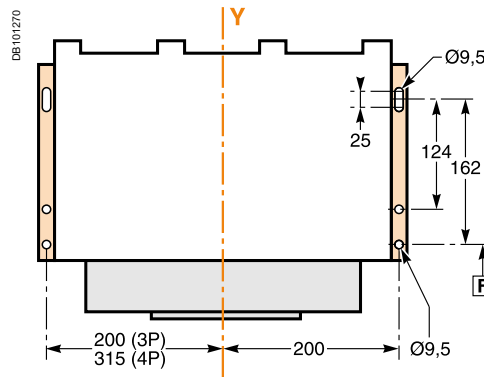

Safety clearances

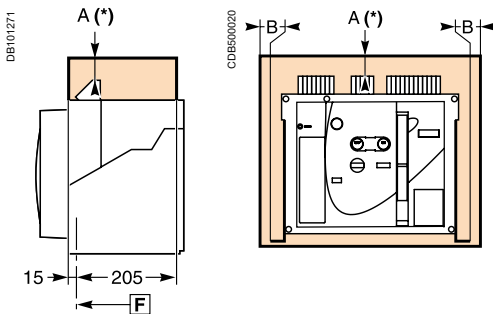

Door cutout

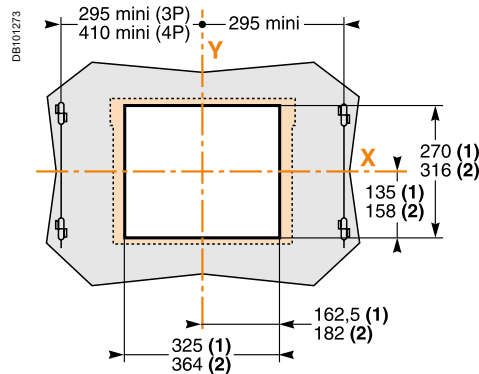

	Insulated parts	Metal parts	Energised parts
A	0	0	100
B	0	0	60

F: Datum.

(1) Without escutcheon.

(2) With escutcheon.

Note: X and Y are the symmetry planes for a 3-pole device.

A(*) An overhead clearance of 110 mm is required to remove the arc chutes.
An overhead clearance of 20 mm is required to remove the terminal block.

MVS Frame 2(4000A) circuit breakers

Fixed 3/4-poles device

Connections

Horizontal rear connection

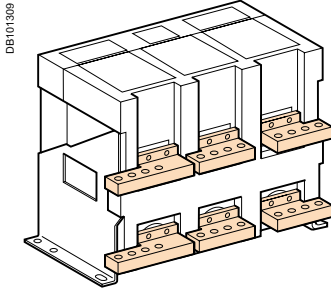

DB101309

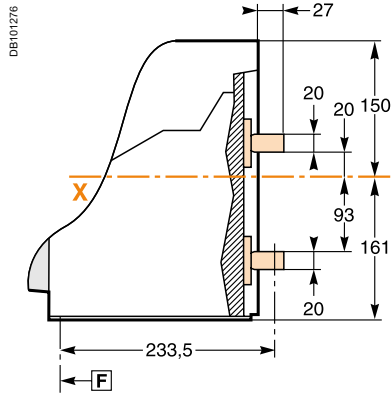

DB101276

Detail

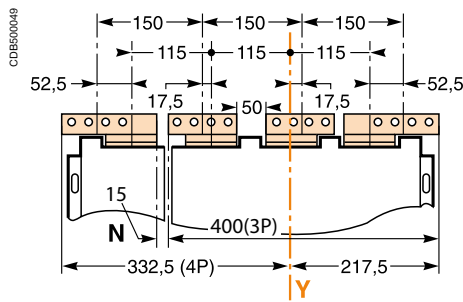

CB850049

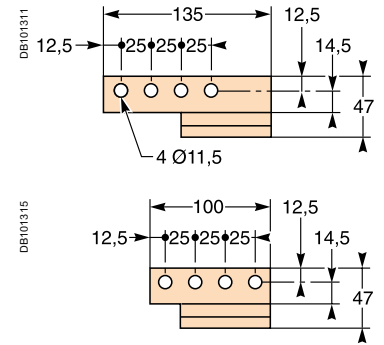

DB101311

DB101315

Vertical rear connection

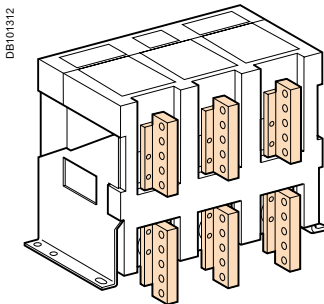

DB101312

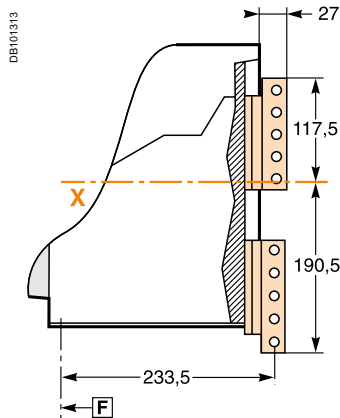

DB101313

Detail

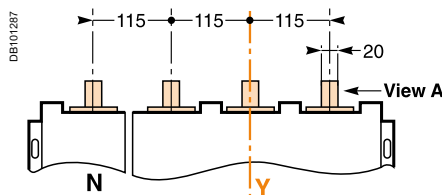

DB101287

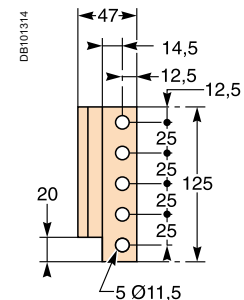

DB101314

Note: Recommended connection screws: **M10** class 8.8.
Tightening torque: **50 Nm** with contact washer.

MVS Frame 2(4000A) circuit breakers

Draw-out 3/4-poles device

Dimensions

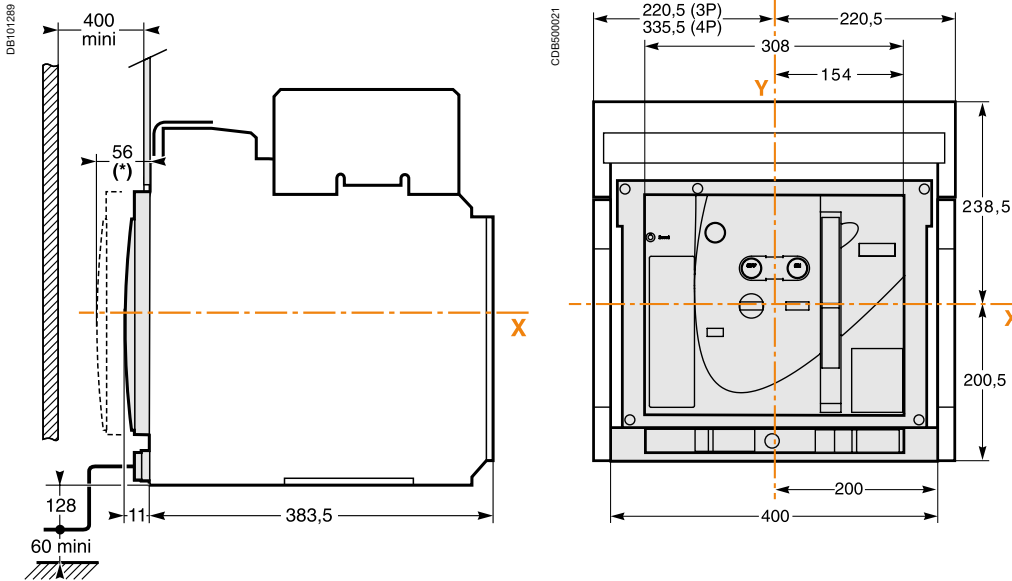

(*) Disconnected position.

Mounting on base plate or rails

Mounting detail

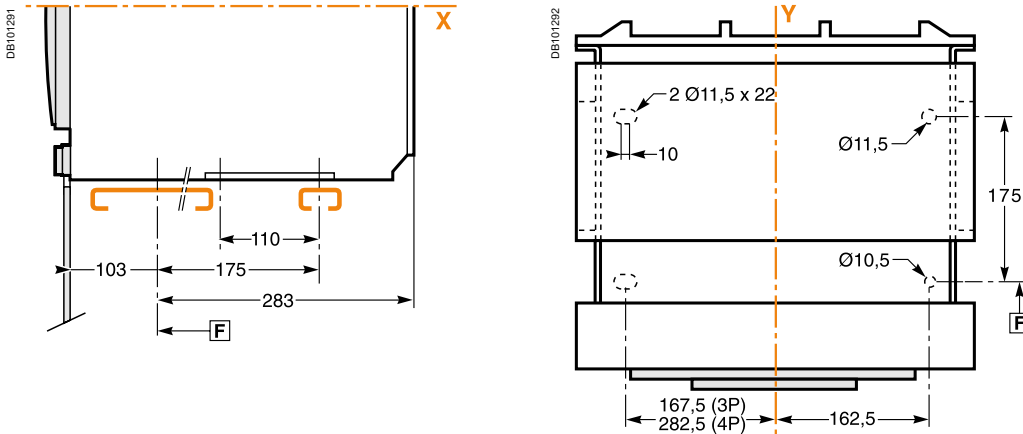

Safety clearances

Door cutout

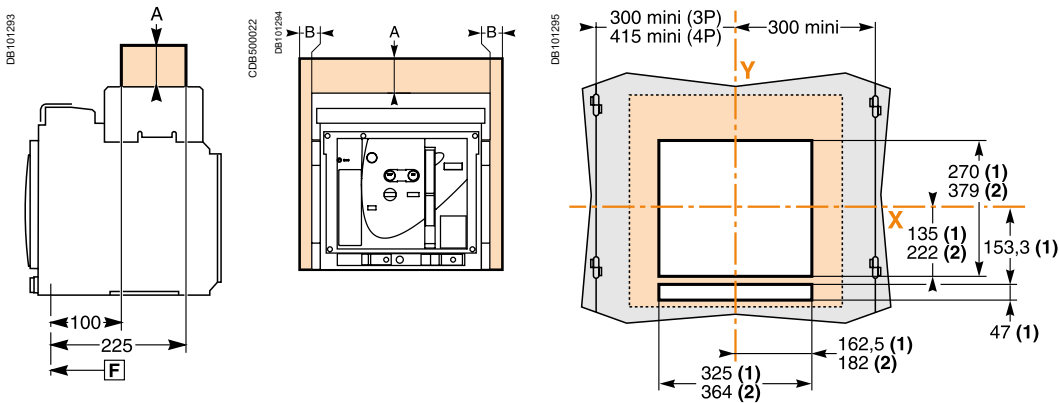

	Insulated parts	Metal parts	Energised parts
A	0	0	60
B	0	0	60

F : Datum.

(1) Without escutcheon.

(2) With escutcheon.

Note: X and Y are the symmetry planes for a 3-pole device.

The safety clearances take into account the space required to remove the arc chutes.

MVS Frame 2(4000A) circuit breakers

Draw-out 3/4-poles device

Connections

Horizontal rear connection

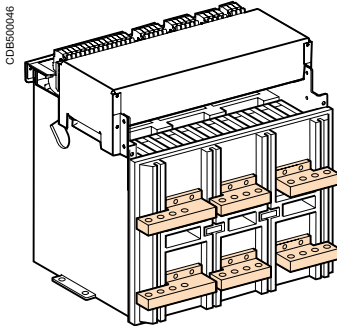

CDB500046

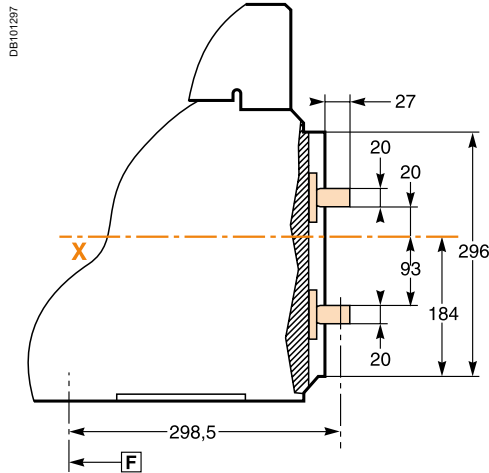

DB101287

Detail

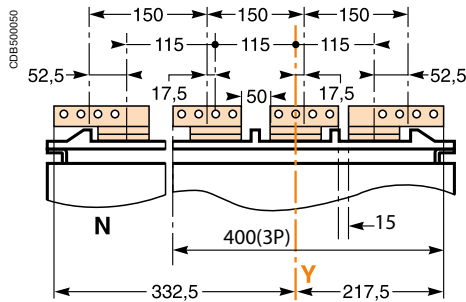

CDB500050

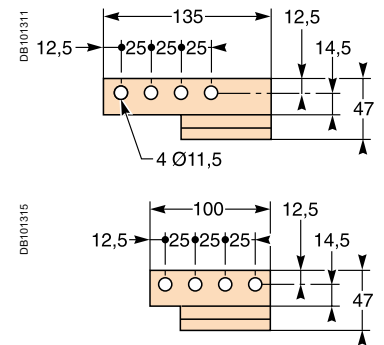

DB101311

DB101315

Vertical rear connection

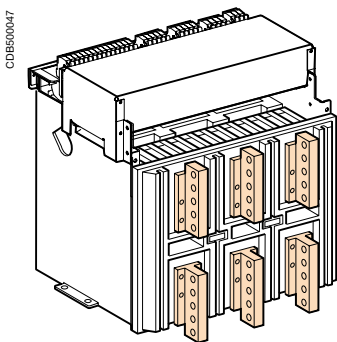

CDB500047

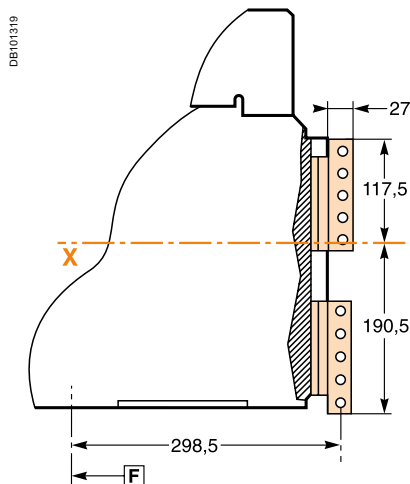

DB101319

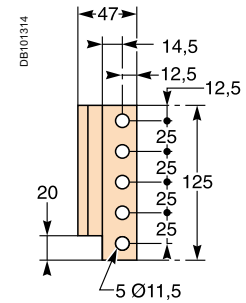

DB101314

View A detail.

Detail

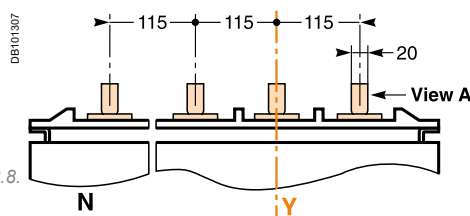

DB101307

Note: Recommended connection screws: **M10** class 8.8.
Tightening torque: **50 Nm** with contact washer.

Mounting on backplate with special brackets (EasyPact MVS08 to 32 fixed)

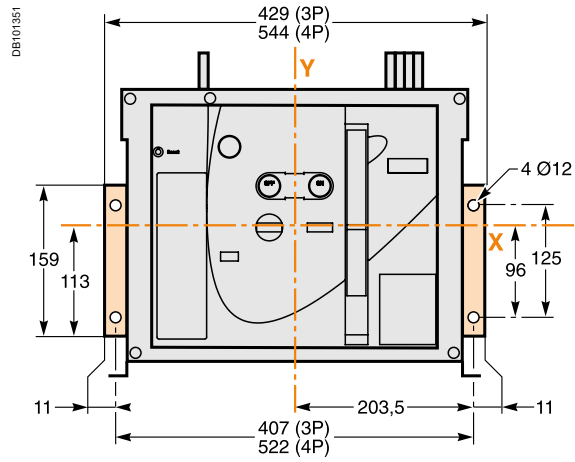
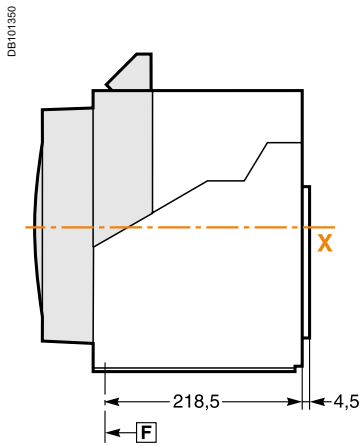

External modules

Connection of auxiliary wiring to terminal block

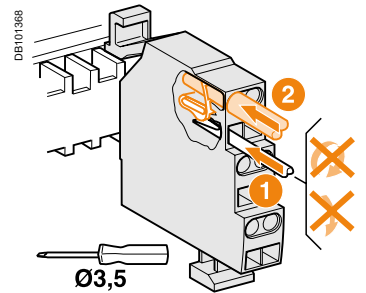
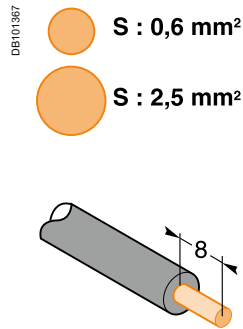

One conductor only per connection point.

External power supply module (AD)

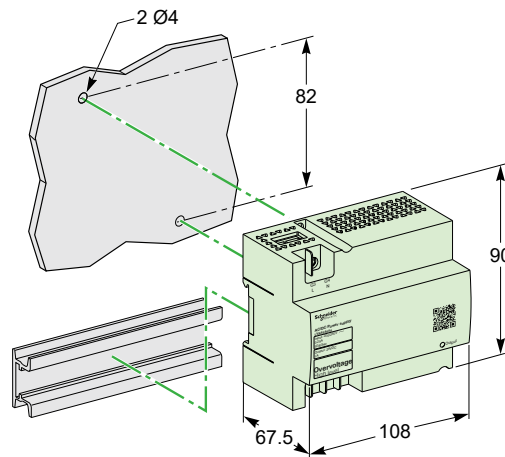
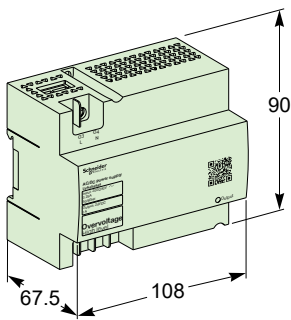

Delay unit for MN release

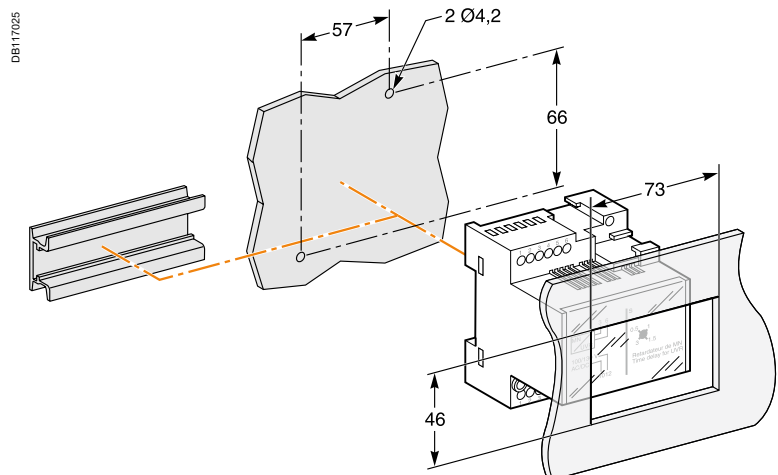
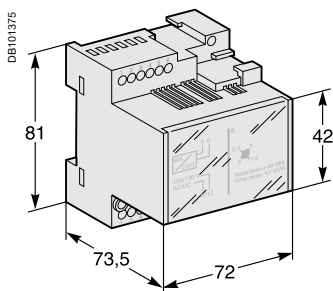

I/O (Input/Output) application module

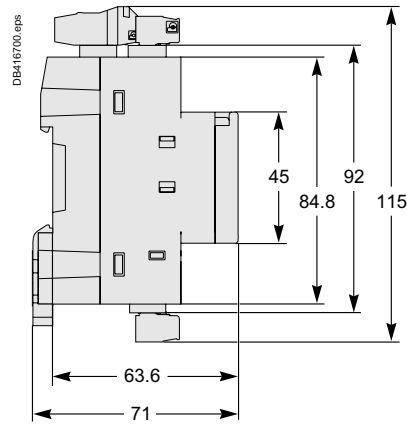
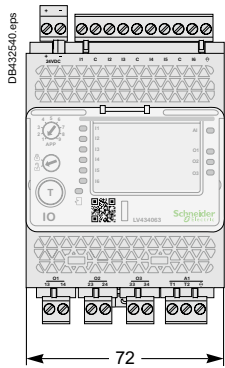

IFM - Modbus-SL interface

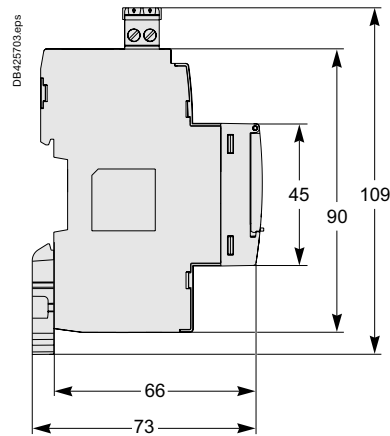
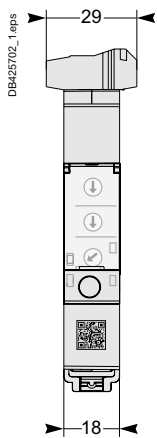

EasyCom-Modbus -Interface

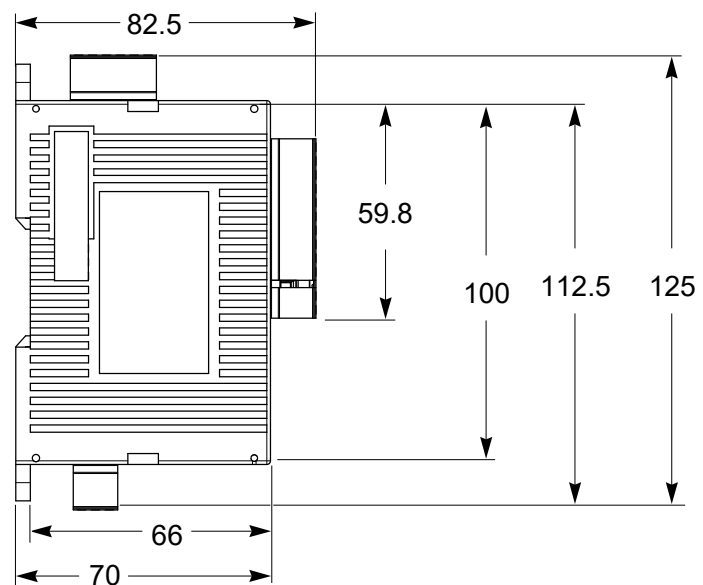
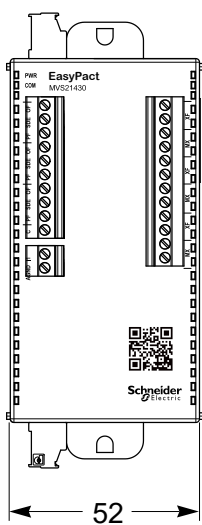

External sensor for external neutral

Dimensions

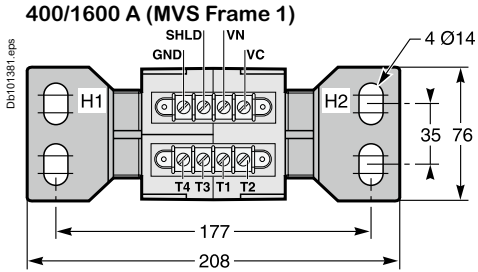

High: 137 mm.

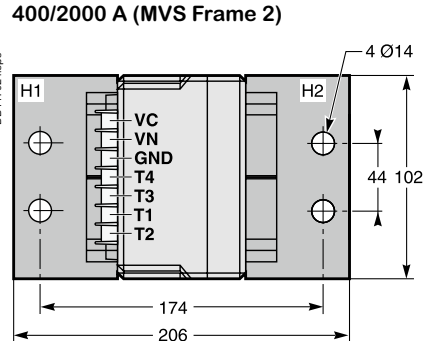

High: 162 mm.

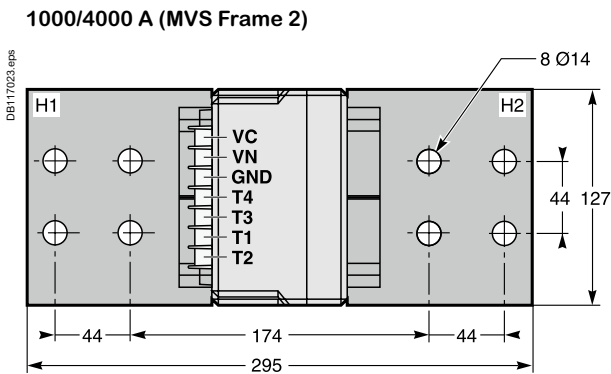

High: 162 mm.

Installation

400/1600 A (MVS Frame 1)

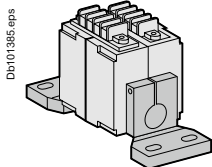

400/2000 A (MVS Frame 2)

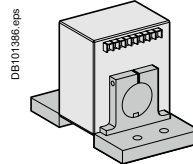

1000/4000 A (MVS Frame 2)

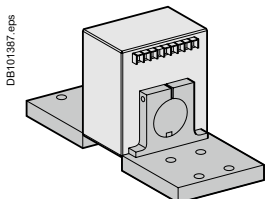

Electrical diagrams



<i>Functions and characteristics</i>	A-1
<i>Installation recommendations</i>	B-1
<i>Dimensions and connection</i>	C-1
EasyPact MVS 06 to 40	D-2
Fixed and draw-out devices	D-2
EasyPact MVS Frame 1	D-3
Fixed and draw-out devices	D-3
EasyPact MVS Frame 2	D-4
Fixed and draw-out devices	D-4
EasyPact MVS	D-5
Earth-fault protection/Neutral protection	D-5
Zone selective interlocking	D-6
24 V DC external power supply AD module	D-7
Fixed EasyPact MVS	D-8
connection to the communication interface module	D-8
Withdrawable EasyPact MVS	D-9
connection to the I/O and communication interface module	D-9
<i>Additional characteristics</i>	E-1
<i>Catalogue numbers and order form</i>	F-1

The diagram is shown with circuits de-energised, all devices open, connected and charged and relays in normal position.

Power

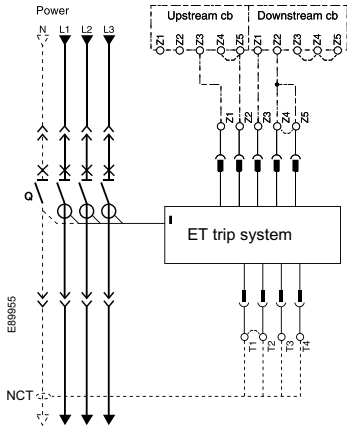

ET/ETA/ETV trip system

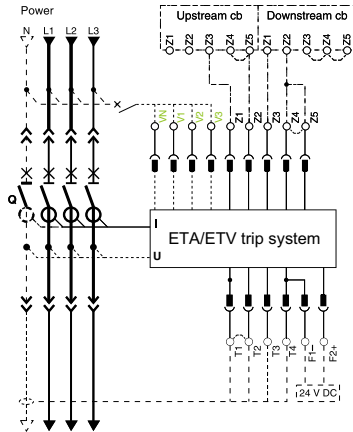

Remote operation

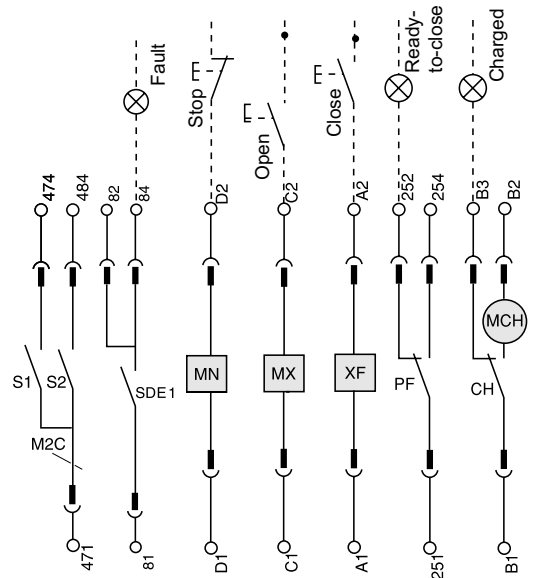

Note: V1...VN Voltage connections are available in ETV trip system.

ET trip system

UC1		UC2	
○	Z5		
○	Z3	○	T3
○	Z4	○	T4
○	Z1	○	T1
○	Z2	○	T2

EA/ETV trip system

Com	UC1	UC2	UC3	M2C
○ E5	○ Z5	○ M1	○ M2	○ M3
			○ F2+	○ 484
○ E3	○ Z3	○ Z4	○ T3	○ T4
			○ VN	○ 474
○ E1	○ Z1	○ Z2	○ T1	○ T2
			○ F1-	○ 471

Remote operation

SDE	MN	MX	XF	PF	MCH
○ 84	○ D2	○ C2	○ A2	○ 254	○ B2
○ 82				○ 252	○ B3
○ 81	○ D1	○ C1	○ A1	○ 251	○ B1

ET/ETA/ETV trip system

UC1 :
 Z1-Z5 zone selective interlocking
 Z1=ZSI OUT SOURCE
 Z2=ZSI OUT ; Z3 = ZSI IN SOURCE
 Z4 =ZSI IN ST (short time)
 Z5 =ZSI IN GF (earth fault)
COM :E1-E6 communication

UC2 :
 T1, T2, T3, T4=external neutral
MC2 : 2 programmable contacts (external relay) ext. 24 V DC power supply required.
UC3 :
 F2+, F1-: external 24 V DC power supply
 VN: external voltage connector (must be connected to the neutral CT with a 3P circuit breaker equipped with ETV trip system)

Remote operation

SDE: Fault-trip indication contact (supplied as standard)
MN: Undervoltage release
MX: Shunt release (standard for Electrical breaker)
XF: Closing release (standard for Electrical breaker)
PF: "Ready to close"contact
MCH: Gear motor (standard for Electrical breaker)

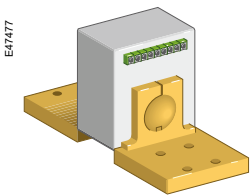

External sensor (CT).

External sensors (Neutral CT)

External sensor for earth-fault protection
 The sensors, used with the 3P circuit breakers, are installed on the neutral conductor for:
 1. Residual type earth-fault protection(ET/ETA/ETV 6G trip system)

The rating of the sensor (CT) must be compatible with the rating of the circuit breaker:

1. MVS frame 1: CT 400/1600;
2. MVS frame 2: CT 400/2000;
3. MVS frame 2: CT 1000/4000;

Indication contacts

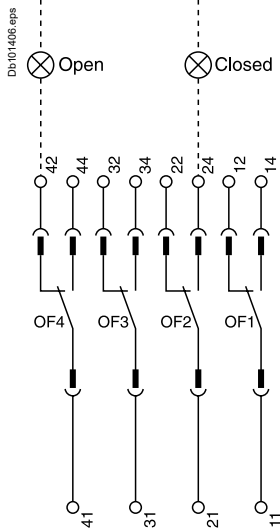

Chassis contacts

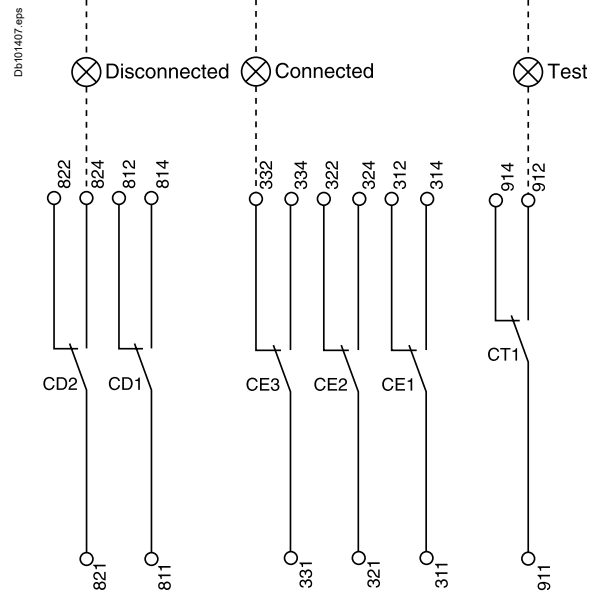

Indication contacts

OF4	OF3	OF2	OF1
44	34	24	14
42	32	22	12
41	31	21	11

Chassis contacts

CD2	CD1	CE3	CE2	CE1	CT1
824	814	334	324	314	914
822	812	332	322	312	912
821	811	331	321	311	911

Indication contacts

OF4 / OF3 / OF2 / OF1 : ON/OFF indication contacts.

(*) Spring charging motor 440/480 V AC
(380 V motor + additional resistor).

Chassis contacts

CD2 : disconnected position contacts
 CD1 : disconnected position contacts
 CE3 : connected position contacts
 CE2 : connected position contacts
 CE1 : connected position contacts
 CT1 : test position contacts

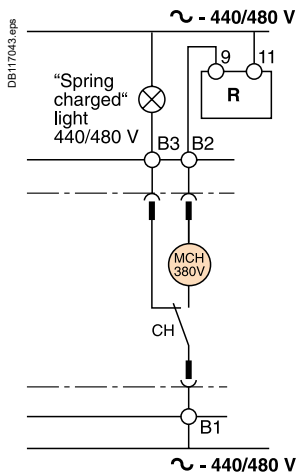

Key:

- drawout device only.
- xxx SDE1, OF1, OF2, OF3, OF4 supplied as standard.
- interconnected connections (only one wire per connection point).

Indication contacts

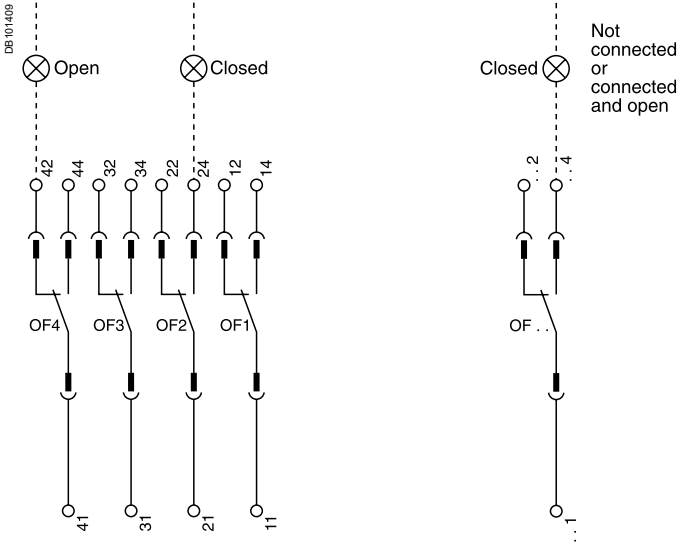

Chassis contacts

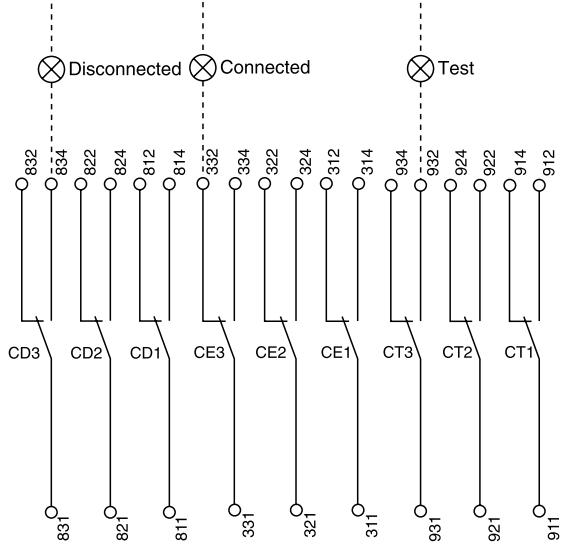

Indication contacts

OF4	OF3	OF2	OF1	OF14	OF13	OF12	OF11
44	34	24	14	144	134	124	114
42	32	22	12	142	132	122	112
41	31	21	11	141	131	121	111

Standard **Optional**

Chassis contacts

CD3	CD2	CD1	CE3	CE2	CE1	CT3	CT2	CT1
834	824	814	334	324	314	934	924	914
832	822	812	332	322	312	932	922	912
831	821	811	331	321	311	931	921	911

Optional

Indication contacts

OF 4	Standard
OF 3	ON/OFF
OF 2	Indication contacts
OF 1	

OF 14	Optional
OF 13	ON/OFF
OF 12	Indication contacts
OF 11	

Chassis contacts

CD3	Disconnected	CE3	Connected	CT3	Test
CD2	Position	CE2	Position	CT2	Position
CD1	Contacts	CE1	Contacts	CT1	Contacts

Key:

- Draw-out device only
- SDE1, OF1, OF2, OF3, OF4 supplied as standard
- Interconnected connections (only one wire per connection point)

External sensor (CT) for residual earth-fault protection

Connection of current-transformer secondary circuit for external neutral

EasyPact MVS equipped with a ET/ETA/ETV 6G:

- Shielded cable with 2 twisted pairs
- T1 twisted with T2
- Maximum length 4 meters
- Cable cross-sectional area 0.4 to 1.5 mm²
- Recommended cable: Belden 9552 or equivalent

For proper wiring of neutral CT, refer to instruction Bulletin 48041-082-03 shipped with it.

Do not remove factory-installed jumper between T1 and T2 unless neutral CT is connected.

If supply is via the top, follow the schematics.

If supply is via the bottom, control wiring is identical; for the power wiring, H1 is connected to the source side, H2 to the load side.

For four-pole versions, for residual earth-fault protection, the current transformer for the external neutral is not necessary.

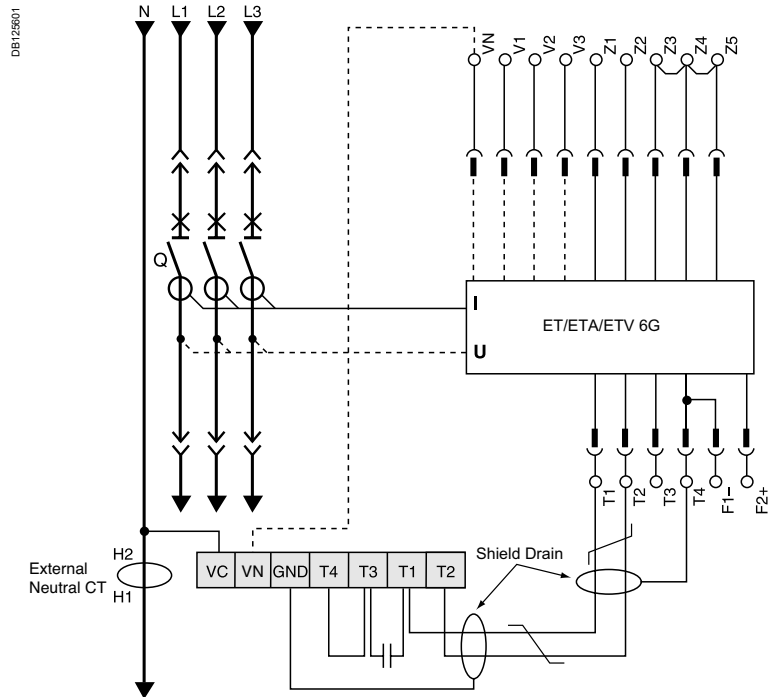

Neutral protection

- Three pole circuit breaker:
 - Neutral protection is impossible
- Four pole circuit breaker:
 - The current transformer for external neutral is not necessary

Zone selective interlocking

Zone-selective interlocking is used to reduce the electrodynamic forces exerted on the installation by shortening the time required to clear faults, while maintaining time discrimination between the various devices.

A pilot wire interconnects a number of circuit breakers equipped with ET range of trip system, as illustrated in the diagram above.

The control unit detecting a fault sends a signal upstream and checks for a signal arriving from downstream. If there is a signal from downstream, the circuit breaker remains closed for the full duration of its tripping delay. If there is no signal from downstream, the circuit breaker opens immediately, regardless of the tripping-delay setting.

Fault 1.

Only circuit breaker A detects the fault. Because it receives no signal from downstream, it opens immediately, regardless of its tripping delay set to 0.3.

Fault 2.

Circuit breakers A and B detect the fault. Circuit breaker A receives a signal from B and remains closed for the full duration of its tripping delay set to 0.3. Circuit breaker B does not receive a signal from downstream and opens immediately, in spite of its tripping delay set to 0.2.

Wiring

- Maximum impedance: 2.7 Ω/ 300 m
- Capacity of connectors: 0.4 to 2.5 mm²
- Wires: single or multicore
- Maximum length: 3000 m
- Limits to device interconnection:
 - The common ZSI - OUT (Z1) and the output ZSI - OUT (Z2) can be connected to a maximum of 10 upstream device
 - A maximum of 100 downstream devices may be connected to the common ZSI - IN (Z3) and to an input ZSI - IN CR (Z4) or GF (Z5)

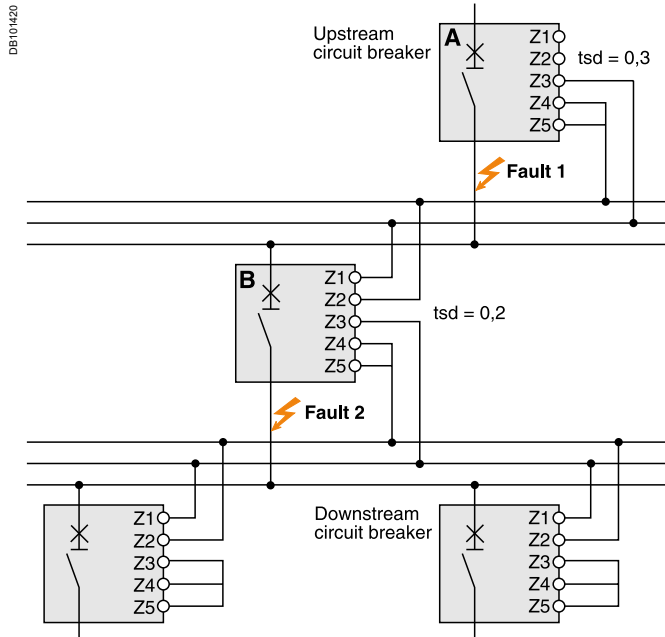

DB11014/20

EasyPact MVS

24 V DC external power supply

AD module

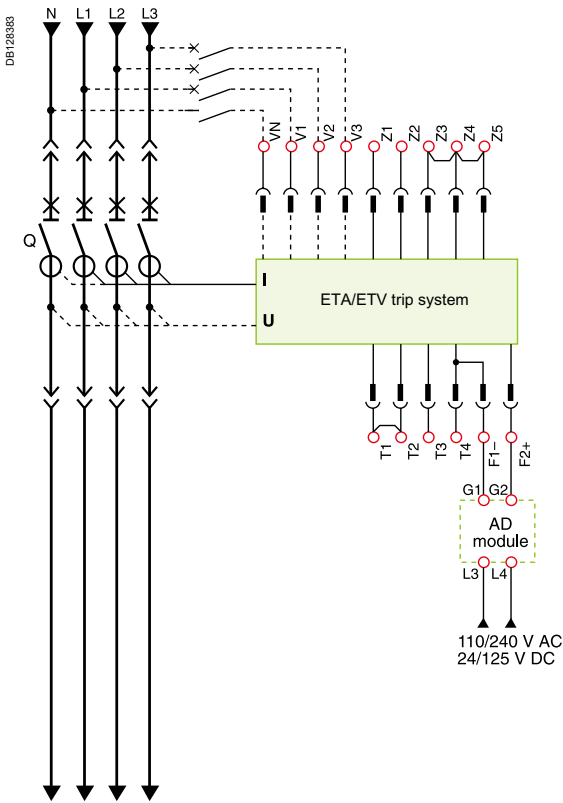

- The 24 V DC external power-supply (AD module) for the ET Trip system (F1- F2+) is not required for basic protections LSIG
- With ETA/ETV, it is recommended to connect 24 V DC external power-supply (AD module) to the Micrologic control unit (F1- F2+) in order to keep available the display and the energy metering, even if Current < 20 % In
- The 24 V DC external power-supply for the BCM ULP communication module(E1-E2) is required. The same 24 V DC external power supply can be used for the communication devices (IFM, I/O, EasyCom)).
- If the 24 V DC external power supply (AD module) is used to supply ET trip system, this power supply shall be used only for supplying ET trip system and M2C.
- The dedicated AD power supplies shall be used only for the ET trip system. If the COM option is used, a second dedicated 24 V DC external power supply shall be used.

Connection

The maximum length for each conductor supplying power to the trip unit is 10 m.

Do not ground F2+, F1-, or power supply output:

- The positive terminal (F2+) on the trip unit must not be connected to earth ground
- The negative terminal (F1-) on the trip unit must not be connected to earth ground
- The output terminals (- and +) of the 24 V DC power supply must not be grounded

Reduce electromagnetic interference:

- The input and output wires of the 24 V DC power supply must be physically separated as much as possible
- If the 24 V DC power supply wires cross power cables, they must cross perpendicularly. If this is not physically possible, the power supply conductors must be twisted together
- Power supply conductors must be cut to length. Do not loop excess conductor

Additional
characteristics



<i>Functions and characteristics</i>	A-1
<i>Installation recommendations</i>	B-1
<i>Dimensions and connection</i>	C-1
<i>Electrical diagrams</i>	D-1
Tripping curves	E-2
Selectivity table	E-4
<i>Catalogue numbers and order form</i>	F-1

Tripping curves

ET range of trip system - 2I

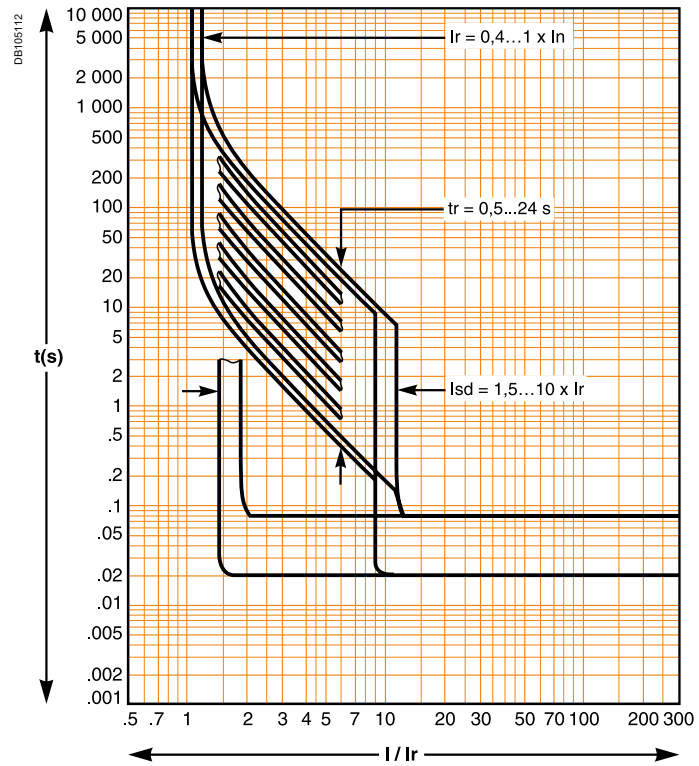

ET range of trip system - 5S, 6G

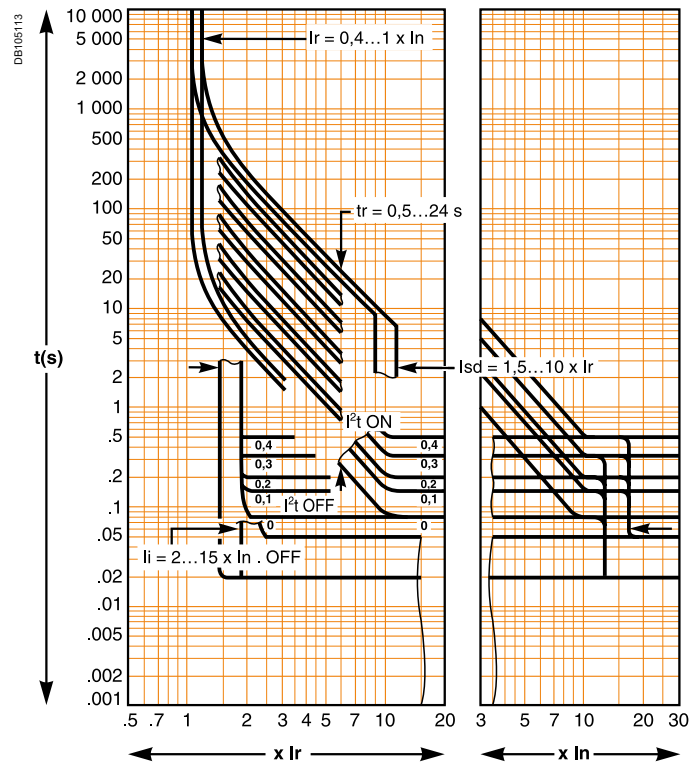

Earth fault protection (ET range of trip system - 6G)

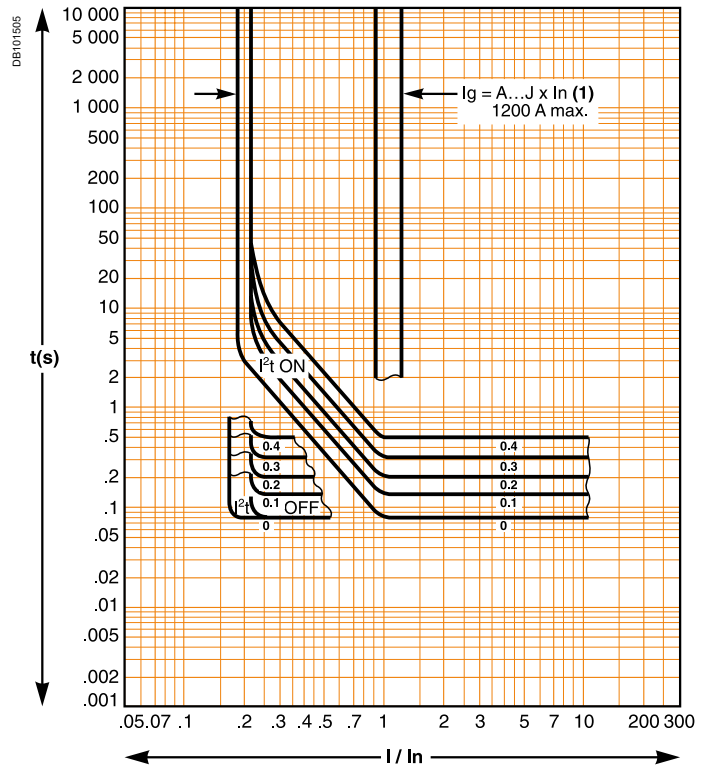

(1)

$I_g = I_n \times \dots$	A	B	C	D	E	F	G	H	I
$I_n \leq 400 \text{ A}$	0.3	0.3	0.4	0.5	0.6	0.7	0.8	0.9	1
$400 \text{ A} < I_n \leq 1000 \text{ A}$	0.2	0.3	0.4	0.5	0.6	0.7	0.8	0.9	1
$I_n \geq 1250 \text{ A}$	500	640	720	800	880	960	1040	1120	1200

Selectivity table

Upstream: **EasyPact MVS**
Downstream: **EasyPact CVS**

Ue ≤ 415 Vac

Upstream Trip Unit		EasyPact MVS C 06-16 ET 2,5,6					EasyPact MVS 08 - 40N ET 2, 5, 6				
Downstream	Rating Setting Ir	630	800	1000	1250	1600	800	1000	1250	1600	2000
Selectivity Limit (kA)											
CVS100 BS TM•D	16	T	T	T	T	T	T	T	T	T	T
	20	T	T	T	T	T	T	T	T	T	T
	25	T	T	T	T	T	T	T	T	T	T
	32	T	T	T	T	T	T	T	T	T	T
	40	T	T	T	T	T	T	T	T	T	T
	50	T	T	T	T	T	T	T	T	T	T
	63	T	T	T	T	T	T	T	T	T	T
	80	T	T	T	T	T	T	T	T	T	T
CVS 100 B/F/N TM•D	16	T	T	T	T	T	T	T	T	T	T
	25	T	T	T	T	T	T	T	T	T	T
	32	T	T	T	T	T	T	T	T	T	T
	40	T	T	T	T	T	T	T	T	T	T
	50	T	T	T	T	T	T	T	T	T	T
	63	T	T	T	T	T	T	T	T	T	T
	80	T	T	T	T	T	T	T	T	T	T
	100	T	T	T	T	T	T	T	T	T	T
CVS 160 B/F/N TM•D	100	T	T	T	T	T	T	T	T	T	T
	125	T	T	T	T	T	T	T	T	T	T
	160	T	T	T	T	T	T	T	T	T	T
CVS 250 B/F/N TM•D	160	T	T	T	T	T	T	T	T	T	T
	200	T	T	T	T	T	T	T	T	T	T
	250	T	T	T	T	T	T	T	T	T	T
CVS 400 F/N TM•D	320	T	T	T	T	T	T	T	T	T	T
	400		T	T	T	T	T	T	T	T	T
CVS 600 F/N TM•D	500		T	T	T	T	T	T	T	T	T
	600			T	T	T		T	T	T	T
CVS 400F/N ETU	320	T	T	T	T	T	T	T	T	T	T
	400	T	T	T	T	T	T	T	T	T	T
CVS 630F/N ETU	500		T	T	T	T	T	T	T	T	T
	630			T	T	T		T	T	T	T

Upstream Trip Unit		EasyPact MVS C 06-16 ET 2,5,6					EasyPact MVS 08 - 40N ET 2, 5, 6				
Downstream	Rating Setting Ir	630	800	1000	1250	1600	800	1000	1250	1600	2000
Motor protection											
CVS 100 B/F MA + O/L R	2.5	T	T	T	T	T	T	T	T	T	T
	6.3	T	T	T	T	T	T	T	T	T	T
	12.5	T	T	T	T	T	T	T	T	T	T
	25	T	T	T	T	T	T	T	T	T	T
	50	T	T	T	T	T	T	T	T	T	T
	100	T	T	T	T	T	T	T	T	T	T
CVS 160 B/F MA + O/L R	100	T	T	T	T	T	T	T	T	T	T
	150	T	T	T	T	T	T	T	T	T	T
CVS 250 B/F MA + O/L R	220	T		T		T	T	T	T	T	T
	250										
CVS 400 F/N MA +O/L R	320			T	T	T		T	T	T	T
	400										
CVS 600 F/N MA +O/L R	500					T				T	T
	630										

Selectivity limit = 4kA

Total selectivity, up to the breaking capacity of the downstream circuit breaker.

No Selectivity

Nota: respect the basic rules of selectivity for overload and short-circuit. See Introduction

Selectivity table

Upstream: EasyPact MVS 06-16

Downstream: EasyPact CVS 06-16

$U_e \leq 415 \text{ Vac}$

Upstream		EasyPact MVS C 06-16														
Trip Unit		ET 2.0 $I_m=10I_r$					ET5.0 - 6.0 $I_m=15I_n$					ET5.0 - 6.0 Inst OFF				
Downstream	Rating Setting Ir	630	800	1000	1250	1600	630	800	1000	1250	1600	630	800	1000	1250	1600
Selectivity limit (kA)																
MVS C 06 ET	250	6.3	8	10	12.5	16	12	12	15	18.75	24	42	42	42	42	42
	320	6.3	8	10	12.5	16	12	12	15	18.75	24	42	42	42	42	42
	400	6.3	8	10	12.5	16	12	12	15	18.75	24	42	42	42	42	42
	500		8	10	12.5	16		12	15	18.75	24		42	42	42	42
	630			10	12.5	16			15	18.75	24			42	42	42
MVS C 08 ET	320	6.3	8	10	12.5	16	12	12	15	18.75	24	42	42	42	42	42
	400	6.3	8	10	12.5	16	12	12	15	18.75	24	42	42	42	42	42
	500		8	10	12.5	16		12	15	18.75	24		42	42	42	42
	630			10	12.5	16			15	18.75	24			42	42	42
	800				12.5	16				18.75	24				42	42
MVS C 10 ET	400	6.3	8	10	12.5	16	12	12	15	18.75	24	42	42	42	42	42
	500		8	10	12.5	16		12	15	18.75	24		42	42	42	42
	630			10	12.5	16			15	18.75	24			42	42	42
	800				12.5	16				18.75	24				42	42
	1000					16					24					42
MVS C 12 ET	500		8	10	12.5	16		12	15	18.75	24		42	42	42	42
	630			10	12.5	16			15	18.75	24			42	42	42
	800				12.5	16				18.75	24				42	42
	1000					16					24					42
	1250															
MVS C 16 ET	630			10	12.5	16			15	18.75	24			42	42	42
	800				12.5	16				18.75	24				42	42
	960					16					24					42
	1250															
	1600															

Selectivity limit = 4kA

Total selectivity, up to the breaking capacity of the downstream circuit breaker.

No Selectivity

Nota: respect the basic rules of selectivity for overload and short-circuit. See Introduction

Selectivity table

Upstream: EasyPact MVS 08-20

Downstream: EasyPact MVS C 06-16,

MVS 08-40 N/H

$U_e \leq 415 \text{ Vac}$

Upstream		EasyPact MVS 08-20 N/H																							
Trip Unit		ET 2.0 $I_m=10I_r$						ET5.0 - 6.0 $I_m=15I_n$						ET5.0 - 6.0 Inst OFF											
Down stream	Rating	800	1000	1250	1600	2000	800	1000	1250	1600	2000	800	1000	1250	1600	2000	800	1000	1250	1600	2000				
	Setting I_r	630	800	1000	1250	1600	2000	630	800	1000	1250	1600	2000	630	800	1000	1250	1600	2000	630	800	1000	1250	1600	2000
Selectivity limit (kA)																									
MVS C 06	400	6.3	8	10	12.5	16	20	12	12	15	18.75	24	30	T	T	T	T	T	T	T	T	T	T		
ET	500		8	10	12.5	16	20		12	15	18.75	24	30		T	T	T	T	T	T	T	T			
	630			10	12.5	16	20			15	18.75	24	30			T	T	T	T	T	T	T			
MVS08 N/H	320	6.3	8	10	12.5	16	20	12	12	15	18.75	24	30	T	T	T	T	T	T	T	T	T			
MVS C 08	400	6.3	8	10	12.5	16	20	12	12	15	18.75	24	30	T	T	T	T	T	T	T	T	T			
	500		8	10	12.5	16	20		12	15	18.75	24	30		T	T	T	T	T	T	T	T			
ET	630			10	12.5	16	20			15	18.75	24	30			T	T	T	T	T	T	T			
	800				12.5	16	20				18.75	24	30				T	T	T	T	T	T			
	1000					16	20					24	30					T	T	T	T	T			
MVS10 N/H	400	6.3	8	10	12.5	16	20	12	12	15	18.75	24	30	T	T	T	T	T	T	T	T	T			
MVS C 10	500		8	10	12.5	16	20		12	15	18.75	24	30		T	T	T	T	T	T	T	T			
	630			10	12.5	16	20			15	18.75	24	30			T	T	T	T	T	T	T			
ET	800				12.5	16	20				18.75	24	30				T	T	T	T	T	T			
	1000					16	20					24	30					T	T	T	T	T			
	1250						20						30							T	T	T			
MVS12 N/H	500		8	10	12.5	16	20		12	15	18.75	24	30		T	T	T	T	T	T	T				
MVS C 12	630			10	12.5	16	20			15	18.75	24	30			T	T	T	T	T	T	T			
	800				12.5	16	20				18.75	24	30				T	T	T	T	T	T			
ET	1000					16	20					24	30					T	T	T	T	T			
	1250						20						30							T	T	T			
	1600																				T	T			
MVS16 N/H	630			10	12.5	16	20			15	18.75	24	30			T	T	T	T	T	T				
MVS C 16	800				12.5	16	20				18.75	24	30				T	T	T	T	T	T			
	960					16	20					24	30					T	T	T	T	T			
ET	1250						20						30								T	T			
	1600																					T			
	1600																								
MVS20 N/H	800				12.5	16	20				18.75	24	30				T	T	T	T	T				
ET	1000					16	20					24	30					T	T	T	T	T			
	1250						20						30								T	T			
	1600																					T			

4 Selectivity limit = 4kA

T Total selectivity, up to the breaking capacity of the downstream circuit breaker.

No Selectivity

Nota: respect the basic rules of selectivity for overload and short-circuit. See Introduction

Selectivity table

Upstream: EasyPact MVS 25-40 N/H

Downstream: EasyPact CVS C 06-16

MVS 08-32 N/H

$U_e \leq 415 \text{ Vac}$

Upstream		EasyPact MVS 08-20 N/H								
Trip Unit		ET 2.0 Im=10I _r			ET5.0 - 6.0 Im=15I _n			ET5.0 - 6.0 Inst OFF		
Downstream	Rating	2500	3200	4000	2500	3200	4000	2500	3200	4000
	Setting I _r	2500	3200	4000	2500	3200	4000	2500	3200	4000
Selectivity limit (kA)										
MVS C 06 ET	<=630	25	32	40	37.5	T	T	T	T	T
MVS C 08 ET	<=800	25	32	40	37.5	T	T	T	T	T
MVS C 10 ET	<=1000	25	32	40	37.5	T	T	T	T	T
MVS C 12 ET	<=1250	25	32	40	37.5	T	T	T	T	T
MVS C 16 ET	<=1600	25	32	40	37.5	T	T	T	T	T
MVS 08 N ET	<=800	25	32	40	37.5	48	T	T	T	T
MVS 10 N ET	<=1000	25	32	40	37.5	48	T	T	T	T
MVS 12 N ET	<=1250	25	32	40	37.5	48	T	T	T	T
MVS 16 N ET	<=1600	25	32	40	37.5	48	T	T	T	T
MVS 16 N ET	<=1600	25	32	40	37.5	48	T	T	T	T
MVS 20 N ET	<=2000	25	32	40	37.5	48	T	T	T	T
MVS 25 N ET	<=2500		32	40		48	T		T	T
MVS 32 N ET	<=3200			40			T			T
MVS 08 H ET	<=800	25	32	40	37.5	48	60	T	T	T
MVS 10 H ET	<=1000	25	32	40	37.5	48	60	T	T	T
MVS 12 H ET	<=1250	25	32	40	37.5	48	60	T	T	T
MVS 16 H ET	<=1600	25	32	40	37.5	48	60	T	T	T
MVS 16 H ET	<=1600	25	32	40	37.5	48	60	T	T	T
MVS 20 H ET	<=2000	25	32	40	37.5	48	60	T	T	T
MVS 25 H ET	<=2500		32	40		48	60		T	T
MVS 32 H ET	<=3200			40			60			T

4 Selectivity limit = 4kA

T Total selectivity, up to the breaking capacity of the downstream circuit breaker.

No Selectivity

Nota: respect the basic rules of selectivity for overload and short-circuit. See Introduction



Catalogue numbers and order form



Catalogue numbers and order form

<i>Functions and characteristics</i>	A-1
<i>Installation recommendations</i>	B-1
<i>Dimensions and connection</i>	C-1
<i>Electrical diagrams</i>	D-1
<i>Tripping curves</i>	E-2
Nomenclature	F-2
EasyPact MVS 630-4000A	F-3
EasyPact MVS Frame 1	F-10
Connection	F-10
ET Trip System & accessories	F-12
EasyPact MVS	F-13
Communication, monitoring and control	F-13
Remote operation	F-14
Chassis locking and accessories	F-15
Circuit breaker locking and accessories	F-16
Mechanical interlocking for source changeover	F-17
EasyPact MVS Frame 2	F-18
Remote operation	F-19
Chassis locking and accessories	F-20
Circuit breaker locking and accessories	F-21
Mechanical interlocking for source changeover	F-22
Indication contacts	F-23
Instructions	F-24
Order form	F-25

Range	Current rating	Type	Pole	Operating mechanism	Installation	Protection No.	Type	
EasyPact MVS (from 630 to 4000A)								
MVS	06	C	3	M	F	2	L	
	08	CA	4	N	W	5	A	
	10	N		O		6	V	
	12	NA		P		0	D	
	16	H		Q				
	20	HA		R				
	25							
	32							
	40							
No. of digits	3	2	1	1	1	1	1	11
								Type
								L Basic protection
								A Protection+Current metering
								V Protection+Energy metering
								D Switch Disconnector
								Protections No.
						2		LJ protection
						5		LSI protection
						6		LSIG protection
						0		No Protection for Switch Disconnector
								Type of installation
					F			Fixed
					W			Withdrawable/drawout
								Operating mechanism
				M				Manually operated ACB/SD
				N				Electrical 200/240 VAC MCH + XF + MX
				O				Electrical 110/130 VAC MCH + XF + MX
				P				Electrical 380/415 VAC MCH + XF + MX
				Q				Electrical 200/250 VDC MCH + XF + MX
				R				Electrical 100/125 VDC MCH + XF + MX
				S				Electrical 48/60V DC MCH + XF + MX
				T				Electrical 24/30V DC MCH + XF + MX
								Number of poles
			3P					3 Poles
			4P					4 Poles
								Type based on breaking capacity
		C						Circuit Breaker I _{cu} =I _{cs} =50kA I _{cw} 1s=35KA(Frame 1: 630-1600A)
		CA						switch disconnector I _{cw} 1s=35KA(Frame 1: 630-1600A)
		N						Circuit Breaker/switch disconnector I _{cu} =I _{cs} =I _{cw} 1s=50KA(Frame 2: 800-4000A)
		H						Circuit Breaker/switch disconnector I _{cu} =I _{cs} =I _{cw} 1s=65KA(Frame 2: 800-4000A)
								Current rating
	06							630A
	08							800A
	10							1000A
	12							1250A
	16							1600A
	20							2000A
	25							2500A
	32							3200A
	40							4000A

Example 1 MVS08C3NW6L

MVS	8	C	3	N	W	6	L
EasyPact MVS	800A	50kA	3 Pole	Electrical operated 200/240 VAC	Withdrawable type	LSIG protection	Basic trip unit with LED indications

Example 2 MVS16CA3MW0D

MVS	16	CA	3	M	W	0	D
EasyPact MVS	1600A	65kA	3 Pole	Manual operated	Withdrawable type	No Protection for Switch Disconnector	Switch Disconnector

EasyPact MVS630-4000A

EasyPact MVS C/CA drawout 50KA

EasyPact MVS C drawout type 50KA with ET trip unit

		3P			4P		
		ET 2I	ET 5S	ET 6G	ET 2I	ET 5S	ET 6G
Manual	630A	MVS06C3MW2L	MVS06C3MW5L	MVS06C3MW6L	*	*	*
	800A	MVS08C3MW2L	MVS08C3MW5L	MVS08C3MW6L	*	*	*
	1000A	MVS10C3MW2L	MVS10C3MW5L	MVS10C3MW6L	*	*	*
	1250A	MVS12C3MW2L	MVS12C3MW5L	MVS12C3MW6L	*	*	*
	1600A	MVS16C3MW2L	MVS16C3MW5L	MVS16C3MW6L	*	*	*
Electrical 240V AC	630A	MVS06C3NW2L	MVS06C3NW5L	MVS06C3NW6L	*	*	*
	800A	MVS08C3NW2L	MVS08C3NW5L	MVS08C3NW6L	*	*	*
	1000A	MVS10C3NW2L	MVS10C3NW5L	MVS10C3NW6L	*	*	*
	1250A	MVS12C3NW2L	MVS12C3NW5L	MVS12C3NW6L	*	*	*
	1600A	MVS16C3NW2L	MVS16C3NW5L	MVS16C3NW6L	*	*	*

EasyPact MVS C drawout type 50KA with ETA trip unit

		3P			4P		
		ETA 2I	ETA 5S	ETA 6G	ETA 2I	ETA 5S	ETA 6G
Manual	630A	MVS06C3MW2A	MVS06C3MW5A	MVS06C3MW6A	*	MVS06C4MW5A	MVS06C4MW6A
	800A	MVS08C3MW2A	MVS08C3MW5A	MVS08C3MW6A	*	MVS08C4MW5A	MVS08C4MW6A
	1000A	MVS10C3MW2A	MVS10C3MW5A	MVS10C3MW6A	*	MVS10C4MW5A	MVS10C4MW6A
	1250A	MVS12C3MW2A	MVS12C3MW5A	MVS12C3MW6A	*	MVS12C4MW5A	MVS12C4MW6A
	1600A	MVS16C3MW2A	MVS16C3MW5A	MVS16C3MW6A	*	MVS16C4MW5A	MVS16C4MW6A
Electrical 240V AC	630A	MVS06C3NW2A	MVS06C3NW5A	MVS06C3NW6A	*	MVS06C4NW5A	MVS06C4NW6A
	800A	MVS08C3NW2A	MVS08C3NW5A	MVS08C3NW6A	*	MVS08C4NW5A	MVS08C4NW6A
	1000A	MVS10C3NW2A	MVS10C3NW5A	MVS10C3NW6A	*	MVS10C4NW5A	MVS10C4NW6A
	1250A	MVS12C3NW2A	MVS12C3NW5A	MVS12C3NW6A	*	MVS12C4NW5A	MVS12C4NW6A
	1600A	MVS16C3NW2A	MVS16C3NW5A	MVS16C3NW6A	*	MVS16C4NW5A	MVS16C4NW6A

EasyPact MVS CA drawout type 50KA switch disconnector

		3P			4P		
Manual	630A	MVS06CA3MW0D			*		
	800A	MVS08CA3MW0D			*		
	1000A	MVS10CA3MW0D			*		
	1250A	MVS12CA3MW0D			*		
	1600A	MVS16CA3MW0D			*		
Electrical 240V AC	630A	*			*		
	800A	*			*		
	1000A	*			*		
	1250A	*			*		
	1600A	*			*		

EasyPact MVS630-4000A

EasyPact MVS C/CA fixed 50KA

EasyPact MVS C fixed type 50KA with ET trip unit

		3P			4P		
		ET 2I	ET 5S	ET 6G	ET 2I	ET 5S	ET 6G
Manual	630A	MVS06C3MF2L	MVS06C3MF5L	MVS06C3MF6L	*	*	*
	800A	MVS08C3MF2L	MVS08C3MF5L	MVS08C3MF6L	*	*	*
	1000A	MVS10C3MF2L	MVS10C3MF5L	MVS10C3MF6L	*	*	*
	1250A	MVS12C3MF2L	MVS12C3MF5L	MVS12C3MF6L	*	*	*
	1600A	MVS16C3MF2L	MVS16C3MF5L	MVS16C3MF6L	*	*	*
Electrical 240V AC	630A	MVS06C3NF2L	MVS06C3NF5L	MVS06C3NF6L	*	*	*
	800A	MVS08C3NF2L	MVS08C3NF5L	MVS08C3NF6L	*	*	*
	1000A	MVS10C3NF2L	MVS10C3NF5L	MVS10C3NF6L	*	*	*
	1250A	MVS12C3NF2L	MVS12C3NF5L	MVS12C3NF6L	*	*	*
	1600A	MVS16C3NF2L	MVS16C3NF5L	MVS16C3NF6L	*	*	*

EasyPact MVS C fixed type 50KA with ETA trip unit

		3P			4P		
		ETA 2I	ETA 5S	ETA 6G	ETA 2I	ETA 5S	ETA 6G
Manual	630A	MVS06C3MF2A	MVS06C3MF5A	MVS06C3MF6A	*	*	*
	800A	MVS08C3MF2A	MVS08C3MF5A	MVS08C3MF6A	*	*	*
	1000A	MVS10C3MF2A	MVS10C3MF5A	MVS10C3MF6A	*	*	*
	1250A	MVS12C3MF2A	MVS12C3MF5A	MVS12C3MF6A	*	*	*
	1600A	MVS16C3MF2A	MVS16C3MF5A	MVS16C3MF6A	*	*	*
Electrical 240V AC	630A	MVS06C3NF2A	MVS06C3NF5A	MVS06C3NF6A	*	*	*
	800A	MVS08C3NF2A	MVS08C3NF5A	MVS08C3NF6A	*	*	*
	1000A	MVS10C3NF2A	MVS10C3NF5A	MVS10C3NF6A	*	*	*
	1250A	MVS12C3NF2A	MVS12C3NF5A	MVS12C3NF6A	*	*	*
	1600A	MVS16C3NF2A	MVS16C3NF5A	MVS16C3NF6A	*	*	*

EasyPact MVS CA fixed type 50kA switch disconnecter

		3P			4P		
Manual	630A	MVS06CA3MF0D			*		
	800A	MVS08CA3MF0D			*		
	1000A	MVS10CA3MF0D			*		
	1250A	MVS12CA3MF0D			*		
	1600A	MVS16CA3MF0D			*		
Electrical 240V AC	630A	*			*		
	800A	*			*		
	1000A	*			*		
	1250A	*			*		
	1600A	*			*		

EasyPact MVS630-4000A

EasyPact MVS N/NA drawout 50KA

EasyPact MVS N drawout type 50KA with ET trip unit

		3P			4P		
		Trip System 2.0	Trip System 5.0	Trip System 6.0	Trip System 2.0	Trip System 5.0	Trip System 6.0
Manual	800A	MVS08N3MW2L	MVS08N3MW5L	MVS08N3MW6L	*	*	*
	1000A	MVS10N3MW2L	MVS10N3MW5L	MVS10N3MW6L	*	*	*
	1250A	MVS12N3MW2L	MVS12N3MW5L	MVS12N3MW6L	*	*	*
	1600A	MVS16N3MW2L	MVS16N3MW5L	MVS16N3MW6L	*	*	*
	2000A	MVS20N3MW2L	MVS20N3MW5L	MVS20N3MW6L	*	*	*
	2500A	MVS25N3MW2L	MVS25N3MW5L	MVS25N3MW6L	*	*	*
	3200A	MVS32N3MW2L	MVS32N3MW5L	MVS32N3MW6L	*	*	*
	4000A	MVS40N3MW2L	MVS40N3MW5L	MVS40N3MW6L	*	*	*
Electrical 240V AC	800A	MVS08N3NW2L	MVS08N3NW5L	MVS08N3NW6L	*	*	*
	1000A	MVS10N3NW2L	MVS10N3NW5L	MVS10N3NW6L	*	*	*
	1250A	MVS12N3NW2L	MVS12N3NW5L	MVS12N3NW6L	*	*	*
	1600A	MVS16N3NW2L	MVS16N3NW5L	MVS16N3NW6L	*	*	*
	2000A	MVS20N3NW2L	MVS20N3NW5L	MVS20N3NW6L	*	*	*
	2500A	MVS25N3NW2L	MVS25N3NW5L	MVS25N3NW6L	*	*	*
	3200A	MVS32N3NW2L	MVS32N3NW5L	MVS32N3NW6L	*	*	*
	4000A	MVS40N3NW2L	MVS40N3NW5L	MVS40N3NW6L	*	*	*

EasyPact MVS N drawout type 50KA with ETA trip unit

		3P			4P		
		ETA 2I	ETA 5S	ETA 6G	ETA 2I	ETA 5S	ETA 6G
Manual	800A	MVS08N3MW2A	MVS08N3MW5A	MVS08N3MW6A	MVS08N4MW2A	MVS08N4MW5A	MVS08N4MW6A
	1000A	MVS10N3MW2A	MVS10N3MW5A	MVS10N3MW6A	MVS10N4MW2A	MVS10N4MW5A	MVS10N4MW6A
	1250A	MVS12N3MW2A	MVS12N3MW5A	MVS12N3MW6A	MVS12N4MW2A	MVS12N4MW5A	MVS12N4MW6A
	1600A	MVS16N3MW2A	MVS16N3MW5A	MVS16N3MW6A	MVS16N4MW2A	MVS16N4MW5A	MVS16N4MW6A
	2000A	MVS20N3MW2A	MVS20N3MW5A	MVS20N3MW6A	MVS20N4MW2A	MVS20N4MW5A	MVS20N4MW6A
	2500A	MVS25N3MW2A	MVS25N3MW5A	MVS25N3MW6A	MVS25N4MW2A	MVS25N4MW5A	MVS25N4MW6A
	3200A	MVS32N3MW2A	MVS32N3MW5A	MVS32N3MW6A	MVS32N4MW2A	MVS32N4MW5A	MVS32N4MW6A
	4000A	MVS40N3MW2A	MVS40N3MW5A	MVS40N3MW6A	MVS40N4MW2A	MVS40N4MW5A	MVS40N4MW6A
Electrical 240V AC	800A	MVS08N3NW2A	MVS08N3NW5A	MVS08N3NW6A	MVS08N4NW2A	MVS08N4NW5A	MVS08N4NW6A
	1000A	MVS10N3NW2A	MVS10N3NW5A	MVS10N3NW6A	MVS10N4NW2A	MVS10N4NW5A	MVS10N4NW6A
	1250A	MVS12N3NW2A	MVS12N3NW5A	MVS12N3NW6A	MVS12N4NW2A	MVS12N4NW5A	MVS12N4NW6A
	1600A	MVS16N3NW2A	MVS16N3NW5A	MVS16N3NW6A	MVS16N4NW2A	MVS16N4NW5A	MVS16N4NW6A
	2000A	MVS20N3NW2A	MVS20N3NW5A	MVS20N3NW6A	MVS20N4NW2A	MVS20N4NW5A	MVS20N4NW6A
	2500A	MVS25N3NW2A	MVS25N3NW5A	MVS25N3NW6A	MVS25N4NW2A	MVS25N4NW5A	MVS25N4NW6A
	3200A	MVS32N3NW2A	MVS32N3NW5A	MVS32N3NW6A	MVS32N4NW2A	MVS32N4NW5A	MVS32N4NW6A
	4000A	MVS40N3NW2A	MVS40N3NW5A	MVS40N3NW6A	MVS40N4NW2A	MVS40N4NW5A	MVS40N4NW6A

EasyPact MVS N drawout type 50KA with ETV trip unit

		3P			4P		
		ETV 2I	ETV 5S	ETV 6G	ETV 2I	ETV 5S	ETV 6G
Manual	800A	MVS08N3MW2V	MVS08N3MW5V	MVS08N3MW6V	MVS08N4MW2V	MVS08N4MW5V	MVS08N4MW6V
	1000A	MVS10N3MW2V	MVS10N3MW5V	MVS10N3MW6V	MVS10N4MW2V	MVS10N4MW5V	MVS10N4MW6V
	1250A	MVS12N3MW2V	MVS12N3MW5V	MVS12N3MW6V	MVS12N4MW2V	MVS12N4MW5V	MVS12N4MW6V
	1600A	MVS16N3MW2V	MVS16N3MW5V	MVS16N3MW6V	MVS16N4MW2V	MVS16N4MW5V	MVS16N4MW6V
	2000A	MVS20N3MW2V	MVS20N3MW5V	MVS20N3MW6V	MVS20N4MW2V	MVS20N4MW5V	MVS20N4MW6V
	2500A	MVS25N3MW2V	MVS25N3MW5V	MVS25N3MW6V	MVS25N4MW2V	MVS25N4MW5V	MVS25N4MW6V
	3200A	MVS32N3MW2V	MVS32N3MW5V	MVS32N3MW6V	MVS32N4MW2V	MVS32N4MW5V	MVS32N4MW6V
	4000A	MVS40N3MW2V	MVS40N3MW5V	MVS40N3MW6V	MVS40N4MW2V	MVS40N4MW5V	MVS40N4MW6V
Electrical 240V AC	800A	MVS08N3NW2V	MVS08N3NW5V	MVS08N3NW6V	MVS08N4NW2V	MVS08N4NW5V	MVS08N4NW6V
	1000A	MVS10N3NW2V	MVS10N3NW5V	MVS10N3NW6V	MVS10N4NW2V	MVS10N4NW5V	MVS10N4NW6V
	1250A	MVS12N3NW2V	MVS12N3NW5V	MVS12N3NW6V	MVS12N4NW2V	MVS12N4NW5V	MVS12N4NW6V
	1600A	MVS16N3NW2V	MVS16N3NW5V	MVS16N3NW6V	MVS16N4NW2V	MVS16N4NW5V	MVS16N4NW6V
	2000A	MVS20N3NW2V	MVS20N3NW5V	MVS20N3NW6V	MVS20N4NW2V	MVS20N4NW5V	MVS20N4NW6V
	2500A	MVS25N3NW2V	MVS25N3NW5V	MVS25N3NW6V	MVS25N4NW2V	MVS25N4NW5V	MVS25N4NW6V
	3200A	MVS32N3NW2V	MVS32N3NW5V	MVS32N3NW6V	MVS32N4NW2V	MVS32N4NW5V	MVS32N4NW6V
	4000A	MVS40N3NW2V	MVS40N3NW5V	MVS40N3NW6V	MVS40N4NW2V	MVS40N4NW5V	MVS40N4NW6V

EasyPact MVS630-4000A

EasyPact MVS N/NA drawout 50KA

EasyPact MVS NA Drawout type 50kA switch disconnecter

		3P			4P		
Manual	800A	MVS08N3MW0D			MVS08N4MW0D		
	1000A	MVS10N3MW0D			MVS10N4MW0D		
	1250A	MVS12N3MW0D			MVS12N4MW0D		
	1600A	MVS16N3MW0D			MVS16N4MW0D		
	2000A	MVS20N3MW0D			MVS20N4MW0D		
	2500A	MVS25N3MW0D			MVS25N4MW0D		
	3200A	MVS32N3MW0D			MVS32N4MW0D		
	4000A	MVS40N3MW0D			MVS40N4MW0D		
Electrical 240V AC	800A	MVS08N3NW0D			MVS08N4NW0D		
	1000A	MVS10N3NW0D			MVS10N4NW0D		
	1250A	MVS12N3NW0D			MVS12N4NW0D		
	1600A	MVS16N3NW0D			MVS16N4NW0D		
	2000A	MVS20N3NW0D			MVS20N4NW0D		
	2500A	MVS25N3NW0D			MVS25N4NW0D		
	3200A	MVS32N3NW0D			MVS32N4NW0D		
	4000A	MVS40N3NW0D			MVS40N4NW0D		

EasyPact MVS630-4000A

EasyPact MVS H/HA drawout 65KA

EasyPact MVS H drawout type 65KA with ET trip unit

		3P			4P		
		Trip System 2.0	Trip System 5.0	Trip System 6.0	Trip System 2.0	Trip System 5.0	Trip System 6.0
Manual	800A	MVS08H3MW2L	MVS08H3MW5L	MVS08H3MW6L	*	*	*
	1000A	MVS10H3MW2L	MVS10H3MW5L	MVS10H3MW6L	*	*	*
	1250A	MVS12H3MW2L	MVS12H3MW5L	MVS12H3MW6L	*	*	*
	1600A	MVS16H3MW2L	MVS16H3MW5L	MVS16H3MW6L	*	*	*
	2000A	MVS20H3MW2L	MVS20H3MW5L	MVS20H3MW6L	*	*	*
	2500A	MVS25H3MW2L	MVS25H3MW5L	MVS25H3MW6L	*	*	*
	3200A	MVS32H3MW2L	MVS32H3MW5L	MVS32H3MW6L	*	*	*
	4000A	MVS40H3MW2L	MVS40H3MW5L	MVS40H3MW6L	*	*	*
Electrical 240V AC	800A	MVS08H3NW2L	MVS08H3NW5L	MVS08H3NW6L	*	*	*
	1000A	MVS10H3NW2L	MVS10H3NW5L	MVS10H3NW6L	*	*	*
	1250A	MVS12H3NW2L	MVS12H3NW5L	MVS12H3NW6L	*	*	*
	1600A	MVS16H3NW2L	MVS16H3NW5L	MVS16H3NW6L	*	*	*
	2000A	MVS20H3NW2L	MVS20H3NW5L	MVS20H3NW6L	*	*	*
	2500A	MVS25H3NW2L	MVS25H3NW5L	MVS25H3NW6L	*	*	*
	3200A	MVS32H3NW2L	MVS32H3NW5L	MVS32H3NW6L	*	*	*
	4000A	MVS40H3NW2L	MVS40H3NW5L	MVS40H3NW6L	*	*	*

EasyPact MVS HA Drawout type 65kA switch disconnecter

		3P			4P		
Manual	800A	MVS08H3MW0D			*		
	1000A	MVS10H3MW0D			*		
	1250A	MVS12H3MW0D			*		
	1600A	MVS16H3MW0D			*		
	2000A	MVS20H3MW0D			*		
	2500A	MVS25H3MW0D			*		
	3200A	MVS32H3MW0D			*		
	4000A	MVS40H3MW0D			*		
Electrical 240V AC	800A	MVS08H3NW0D			*		
	1000A	MVS10H3NW0D			*		
	1250A	MVS12H3NW0D			*		
	1600A	MVS16H3NW0D			*		
	2000A	MVS20H3NW0D			*		
	2500A	MVS25H3NW0D			*		
	3200A	MVS32H3NW0D			*		
	4000A	MVS40H3NW0D			*		

EasyPact MVS630-4000A

EasyPact MVS N/NA fixed 50KA

EasyPact MVS N fixedtype 50KA with ET trip unit

		3P			4P		
		Trip System 2.0	Trip System 5.0	Trip System 6.0	Trip System 2.0	Trip System 5.0	Trip System 6.0
Manual	800A	MVS08N3MF2L	MVS08N3MF5L	MVS08N3MF6L	*	*	*
	1000A	MVS10N3MF2L	MVS10N3MF5L	MVS10N3MF6L	*	*	*
	1250A	MVS12N3MF2L	MVS12N3MF5L	MVS12N3MF6L	*	*	*
	1600A	MVS16N3MF2L	MVS16N3MF5L	MVS16N3MF6L	*	*	*
	2000A	MVS20N3MF2L	MVS20N3MF5L	MVS20N3MF6L	*	*	*
	2500A	MVS25N3MF2L	MVS25N3MF5L	MVS25N3MF6L	*	*	*
	3200A	MVS32N3MF2L	MVS32N3MF5L	MVS32N3MF6L	*	*	*
	4000A	MVS40N3MF2L	MVS40N3MF5L	MVS40N3MF6L	*	*	*
Electrical 240V AC	800A	MVS08N3NF2L	MVS08N3NF5L	MVS08N3NF6L	*	*	*
	1000A	MVS10N3NF2L	MVS10N3NF5L	MVS10N3NF6L	*	*	*
	1250A	MVS12N3NF2L	MVS12N3NF5L	MVS12N3NF6L	*	*	*
	1600A	MVS16N3NF2L	MVS16N3NF5L	MVS16N3NF6L	*	*	*
	2000A	MVS20N3NF2L	MVS20N3NF5L	MVS20N3NF6L	*	*	*
	2500A	MVS25N3NF2L	MVS25N3NF5L	MVS25N3NF6L	*	*	*
	3200A	MVS32N3NF2L	MVS32N3NF5L	MVS32N3NF6L	*	*	*
	4000A	MVS40N3NF2L	MVS40N3NF5L	MVS40N3NF6L	*	*	*

EasyPact MVS NA fixedtype 50kA switch disconnecter

		3P			4P		
Manual	800A	MVS08N3MF0D			*		
	1000A	MVS10N3MF0D			*		
	1250A	MVS12N3MF0D			*		
	1600A	MVS16N3MF0D			*		
	2000A	MVS20N3MF0D			*		
	2500A	MVS25N3MF0D			*		
	3200A	MVS32N3MF0D			*		
	4000A	MVS40N3MF0D			*		
Electrical 240V AC	800A	MVS08N3NF0D			*		
	1000A	MVS10N3NF0D			*		
	1250A	MVS12N3NF0D			*		
	1600A	MVS16N3NF0D			*		
	2000A	MVS20N3NF0D			*		
	2500A	MVS25N3NF0D			*		
	3200A	MVS32N3NF0D			*		
	4000A	MVS40N3NF0D			*		

EasyPact MVS630-4000A

EasyPact MVS H/HA fixed65KA

EasyPact MVS H fixedtype 65KA with ET trip unit

		3P			4P		
		Trip System 2.0	Trip System 5.0	Trip System 6.0	Trip System 2.0	Trip System 5.0	Trip System 6.0
Manual	800A	MVS08H3MF2L	MVS08H3MF5L	MVS08H3MF6L	*	*	*
	1000A	MVS10H3MF2L	MVS10H3MF5L	MVS10H3MF6L	*	*	*
	1250A	MVS12H3MF2L	MVS12H3MF5L	MVS12H3MF6L	*	*	*
	1600A	MVS16H3MF2L	MVS16H3MF5L	MVS16H3MF6L	*	*	*
	2000A	MVS20H3MF2L	MVS20H3MF5L	MVS20H3MF6L	*	*	*
	2500A	MVS25H3MF2L	MVS25H3MF5L	MVS25H3MF6L	*	*	*
	3200A	MVS32H3MF2L	MVS32H3MF5L	MVS32H3MF6L	*	*	*
	4000A	MVS40H3MF2L	MVS40H3MF5L	MVS40H3MF6L	*	*	*
Electrical 240V AC	800A	MVS08H3NF2L	MVS08H3NF5L	MVS08H3NF6L	*	*	*
	1000A	MVS10H3NF2L	MVS10H3NF5L	MVS10H3NF6L	*	*	*
	1250A	MVS12H3NF2L	MVS12H3NF5L	MVS12H3NF6L	*	*	*
	1600A	MVS16H3NF2L	MVS16H3NF5L	MVS16H3NF6L	*	*	*
	2000A	MVS20H3NF2L	MVS20H3NF5L	MVS20H3NF6L	*	*	*
	2500A	MVS25H3NF2L	MVS25H3NF5L	MVS25H3NF6L	*	*	*
	3200A	MVS32H3NF2L	MVS32H3NF5L	MVS32H3NF6L	*	*	*
	4000A	MVS40H3NF2L	MVS40H3NF5L	MVS40H3NF6L	*	*	*

EasyPact MVS HA fixedtype 65kA switch disconnecter

		3P			4P		
Manual	800A	MVS08H3MF0D			*		
	1000A	MVS10H3MF0D			*		
	1250A	MVS12H3MF0D			*		
	1600A	MVS16H3MF0D			*		
	2000A	MVS20H3MF0D			*		
	2500A	MVS25H3MF0D			*		
	3200A	MVS32H3MF0D			*		
	4000A	MVS40H3MF0D			*		
Electrical 240V AC	800A	MVS08H3NF0D			*		
	1000A	MVS10H3NF0D			*		
	1250A	MVS12H3NF0D			*		
	1600A	MVS16H3NF0D			*		
	2000A	MVS20H3NF0D			*		
	2500A	MVS25H3NF0D			*		
	3200A	MVS32H3NF0D			*		
	4000A	MVS40H3NF0D			*		

Connection -MVS Frame 1

Fixed circuit breakers

3P

4P

Rear connection (vertical or horizontal mounting) / Replacement kit (3 or 4 parts)

DB402835-NEV/Val

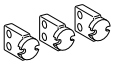

DB402838-NEV/Val

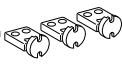

250/630-1600 A

33584

33585

Vert. mounting. Horiz. mounting. Installation manual

MVS21735

Drawout circuit breakers

Rear connection (vertical or horizontal mounting) / Replacement kit (3 or 4 parts)

DB402835-NEV/Val

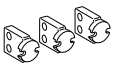

DB402838-NEV/Val

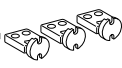

250/630-1600 A

33586

33587

Vert. mounting. Horiz. mounting. Installation manual

MVS21735

Connection accessories -MVS Frame 1

Interphase barriers / Replacement kit (3 parts)

DB404352-NEV/Val



For fixed front and rear-connected circuit breakers
(take 2 kits : 1 for the top, 1 for the bottom connections)

33648

33648

DB128433-eps



For drawout rear-connected circuit breakers (the same kit covers
the top and the bottom connections on the same time)
Installation manual

33768

33768

47102

Connection MVS Frame 2

Fixed circuit breakers

Rear connection (vertical or horizontal mounting) / Replacement kit (3 or 4 parts)

E46445

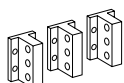

Vertical mounting.

		3P	4P
800-2000 A	Vertical	47964	47965
	Horizontal	47964	47965
2500/3200 A	Vertical	47966	47967
	Horizontal	47966	47967
4000 A	Vertical	47968	47969
	Horizontal	47970	47971

E46446

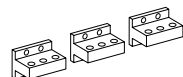

Horizontal mounting.

Installation manual	MVS21735
---------------------	----------

Draw-out circuit breakers

Rear connection (vertical or horizontal mounting) / Replacement kit (3 or 4 parts)

E46445

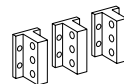

Vertical mounting.

		3P	4P
800-2000 A	Vertical	47964	47965
	Horizontal	47964	47965
2500/3200 A	Vertical	47966	47967
	Horizontal	47966	47967
4000 A	Vertical	47968	47969
	Horizontal	47970	47971

E46446

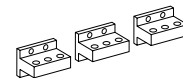

Horizontal mounting.

Installation manual	MVS21735
---------------------	----------

Connection accessories-MVS Frame 2

Interphase barriers / Replacement kit (3 parts)

E46428

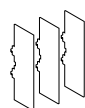

For fixed rear-connected circuit breaker	48599	48599
For draw-out rear-connected circuit breaker	48600	48600
Installation manual	MVS21735	

EasyPact MVS

ET Trip System & accessories

ET trip units & accessories

Battery + cover

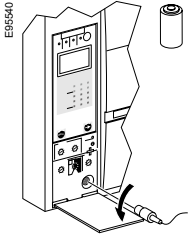

Battery (1 part)	33593
Cover (1 part)	33592

External sensors

External sensor for earth-fault protection (TCE) / 1 part

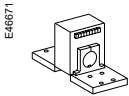

Sensor rating	400/1600 A	33576
	400/2000A	34035
	1000/4000 A	34036

External power supply module (AD) / 1 part

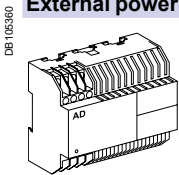



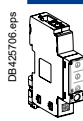
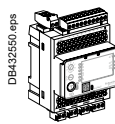

24-30 V DC	LV454440
48-60 V DC	LV454441
200-240 V AC	Lv454444

Communication option

	IFM Modbus-SL interface module	LV434000
	I/O application module	LV434063
	6 wires terminals drawout (1 part)	47850
	6 wires terminals fixed (1 part)	47075
	User guide I/O application module	DOCA0055EN-00

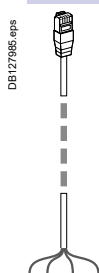
Monitoring and control

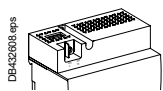
ULP wiring accessories

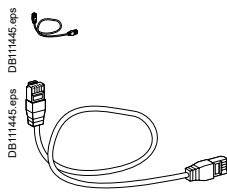
	Breaker ULP cord L = 0.35 m	LV434195
	Breaker ULP cord L = 1.3 m	LV434196
	Breaker ULP cord L = 3 m	LV434197
	10 stacking connectors for communication interface modules	TRV00217
	2 Modbus line terminators	VW3A8306DRC ⁽²⁾
	5 RJ45 connectors female/female	TRV00870
	10 ULP line terminators	TRV00880
	10 RJ45/RJ45 male cord L = 0.3 m	TRV00803
	10 RJ45/RJ45 male cord L = 0.6 m	TRV00806
	5 RJ45/RJ45 male cord L = 1 m	TRV00810
	5 RJ45/RJ45 male cord L = 2 m	TRV00820
	5 RJ45/RJ45 male cord L = 3 m	TRV00830
	1 RJ45/RJ45 male cord L = 5 m	TRV00850

Remote operation

Gear motor

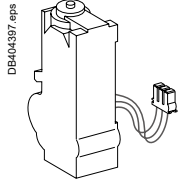

MCH (1 part)

AC 50/60 Hz	100/130 V	33176
	200/240 V	33177
	277/415 V	33179
DC	24/30 V	33185
	48/60 V	33186
	100/125 V	33187
	200/250 V	33188
	Terminal block (1 part)	For fixed circuit breaker
	For drawout circuit breaker	33098

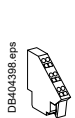

Fixed.

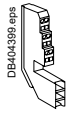

Drawout.

Installation manual

MVS21736

Closing and opening release (XF or MX)

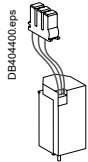

Standard coil (1 part)

AC 50/60 Hz	24/30 V DC, 24 V AC	33659	
	DC	48/60 V DC, 48 V AC	33660
		100/130 V AC/DC	33661
		200/250 V AC/DC	33662
		277 V AC	33663
		380/480 V AC	33664
Terminal block (1 part)	For fixed circuit breaker	47074	
	For drawout circuit breaker	33098	

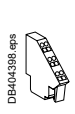

Fixed.

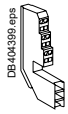

Drawout.

Installation manual

MVS21736

Undervoltage release MN

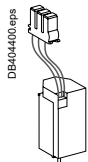

Undervoltage release (1 part)

AC 50/60 Hz	24/30 V DC, 24 V AC	33668	
	DC	48/60 V DC, 48 V AC	33669
		100/130 V AC/DC	33670
		200/250 V AC/DC	33671
		380/480 V AC	33673
Terminal block (1 part)	For fixed circuit breaker	47074	
	For drawout circuit breaker	33098	

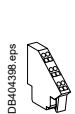

Fixed.

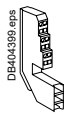

Drawout.

Installation manual

47103

MN delay unit

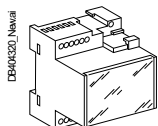

MN delay unit (1 part)

AC 50/60 Hz	48/60 V AC/DC	R (non-adjustable)	Rr (adjustable)
		33684	33681
	DC	100/130 V AC/DC	33682
		200/250 V AC/DC	33683
	380/480 V AC/DC		
Installation manual			MVS21736

Chassis locking

"Disconnected" position locking / 1 part

DB642875_1Newall

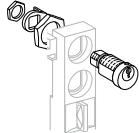

By padlocks		
	VCPO	Standard
By Profalux keylocks		
Profalux	1 lock with 1 key + adaptation kit	64909
	2 locks 1 key + adaptation kit	64910
1 keylock Profalux (without adaptation kit):	identical key not identified combination	33173
By Ronis keylocks		
Ronis	1 lock with 1 key + adaptation kit	64912
	2 locks 1 key + adaptation kit	64913
	2 locks 2 different keys + adaptation kit	64914
1 keylock Ronis (without adaptation kit):	identical key not identified combination	33189
Adaptation kit (without keylock):	adaptation kit Profalux	33769
	adaptation kit Ronis	33770
Installation manual		MVS21737

Door interlock / 1 part

DB640401_1Newall

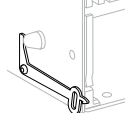

Right and left-hand side of chassis (VPECD or VPECG)	33172
Installation manual	MVS21737

Chassis accessories

Auxiliary terminal shield (CB) / 1 part

DB642877_1Newall

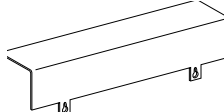

Terminal shield	3P	33763
	4P	33764
Installation manual		MVS21737

Safety shutters + locking / 1 part

DB644403_1EN16a

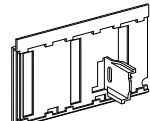

Safety shutters (VO)	3P	33765
	4P	33766
Installation manual		MVS21737

Note: the locking of safety shutters is integrated.

Circuit breaker locking

OFF position locking / 1 part

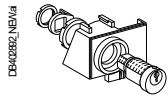

By Profalux keylocks + BPF support

Profalux	1 lock with 1 key + adaptation kit	47515M
1 keylock Profalux (without adaptation kit):	identical key not identified combination	33173

By Ronis keylocks + BPF support

Ronis	1 lock with 1 key + adaptation kit	64920
1 keylock Ronis (without adaptation kit):	identical key not identified combination	33189
Adaptation kit (without keylock):	adaptation kit Profalux	47515
	adaptation kit Ronis	47516
Installation manual		MVS21737

Other circuit breaker accessories

Escutcheon and accessories / 1 part

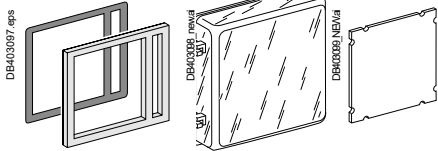

	Fixed	Drawout
Escutcheon	33718	33857
Transparent cover (IP54)		33859
Escutcheon blanking plate		33858
Installation manual		MVS21737

Escutcheon

Cover

Blanking plate

Mechanical interlocking for source changeover

Interlocking using cables ⁽¹⁾

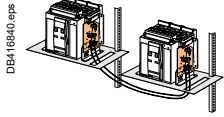

DB416840_eps

Choose 2 adaptation fixtures (1 for each breaker) + 1 set of cables	
1 adaptation fixture for MVS Frame 1 fixed devices	33200
1 adaptation fixture for MVS Frame 1 drawout devices	33201
1 set of 2 cables	33209

(1) Can be used with any combination of MVS, fixed or drawout devices.

Indication contacts

"Ready to close" contact (1 max.) / 1 part

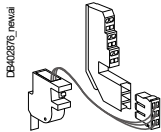

DB402976_newad

1 changeover contact (6 A - 240 V)	PF
	47080
Wiring	For fixed circuit breaker
	47074
	For drawout circuit breaker
	33098
Installation manual	MVS 21736

Carriage switches (connected / disconnected / test position) / 1 part



DB402976_newad

Changeover contacts (6 A - 240 V)	
1 connected position contact (3 max.)	33170
1 test position contact (1 max.)	33170
1 disconnected position contact (2 max.)	33170

Auxiliary terminals for chassis alone

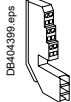

DB404389_eps

3 wire terminal (1 part), terminal block (1 part)	33098
6 wires terminals drawout (1 part)	33099
Installation manual	MVS 21736

Remote operation

Gear motor

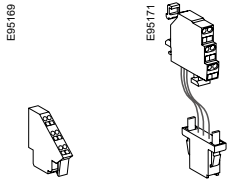
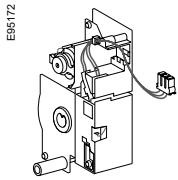

Fixed.

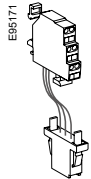

Draw-out.

MCH (1 part)

AC 50/60 Hz	100/130 V	47893
	200/240 V	47894
	380/415 V	47896
DC	24/30 V	47888
	48/60 V	47889
	100/125 V	47890
	200/250 V	47891
	Terminal block (1 part)	For fixed circuit breaker
	For draw-out circuit breaker	47849

Installation manual

MVS21736

Closing release (XF)

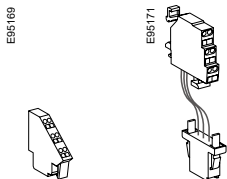
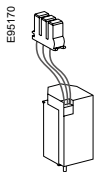

Fixed.

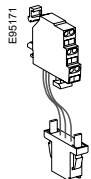

Draw-out.

Standard coil (1 part)

AC 50/60 Hz	24/30 V DC, 24 V AC	33659
	48/60 V DC, 48 V AC	33660
DC	100/130 V AC/DC	MVS15511
	200/250 V AC/DC	MVS15512
	380/480 V AC	MVS15513
	Terminal block (1 part)	For fixed circuit breaker
	For draw-out circuit breaker	47849

Installation manual

MVS21736

Opening release (MX)

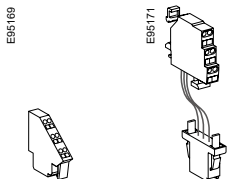
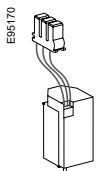

Fixed.

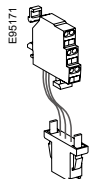

Draw-out.

Standard coil (1 part)

AC 50/60 Hz	24/30 V DC, 24 V AC	33659
	48/60 V DC, 48 V AC	33660
DC	100/130 V AC/DC	33661
	200/250 V AC/DC	33662
	380/480 V AC	33664
	Terminal block (1 part)	For fixed circuit breaker
	For draw-out circuit breaker	47849
Installation manual		MVS21736

Remote operation

Undervoltage release MN

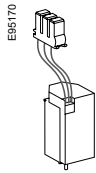

E85169

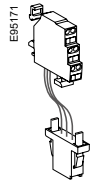

Fixed.

Draw-out.

Undervoltage release (1 part)

AC 50/60 Hz	24/30 V DC, 24 V AC	33668
	DC	33669
	100/130 V AC/DC	33670
	200/250 V AC/DC	33671
	380/480 V AC	33673
Terminal block (1 part)	For fixed circuit breaker	47074
	For draw-out circuit breaker	47849

Installation manual	MVS21736
---------------------	----------

MN delay unit

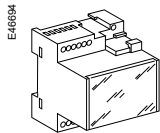

MN delay unit (1 part)

		R (non-adjustable)	Rr (adjustable)
AC 50/60 Hz	48/60 V AC/DC		33680
	DC	33684	33681
	100/130 V AC/DC		33682
	200/250 V AC/DC	33685	33683
	380/480 V AC/DC		33683
Installation manual			MVS21736

Chassis locking

"Disconnected" position locking / 1 part

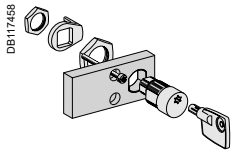

By padlocks

VCPO	Standard
------	----------

By Profalux keylocks

Profalux	1 lock with 1 key + adaptation kit	64934
	2 locks 1 key + adaptation kit	64935
	Profalux 1 lock+ 1 key (without adaptation kit)	42888
	Profalux 2 locks + 1 key (without adaptation kit)	42878
	Adaptation kit (without key locks)	48564

By Ronis keylocks

Ronis	1 lock with 1 key + adaptation kit	64937
	2 locks 1 key + adaptation kit	64938
	Ronis 1 lock+ 1 key (without adaptation kit)	41940
	Ronis 2 locks + 1 key (without adaptation kit)	41950
	Adaptation kit (without key locks)	48564

Installation manual	MVS21737
---------------------	----------

Door interlock / 1 part

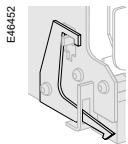

Right and left-hand side of chassis (VPECD or VPECG)	47914
--	-------

Installation manual	MVS21737
---------------------	----------

Chassis accessories

Auxiliary terminal shield (CB) / 1 part

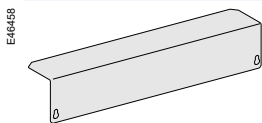

800/4000 A	3P	64942
	4P	48596

Installation manual	MVS21737
---------------------	----------

Safety shutters + locking block / 1 part

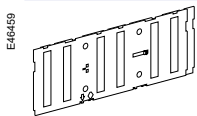

800/4000 A	3P	48721
	4P	48723

Installation manual	MVS21737
---------------------	----------

Shutter locking block (for replacement) / 1 part

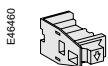

2 parts for 800/4000 A	48591
------------------------	-------

Installation manual	MVS21737
---------------------	----------

Racking handle

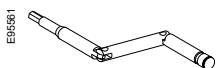

Racking handle	47944
----------------	-------

Circuit breaker locking

Pushbutton locking device / 1 part

E46866

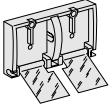

By padlocks	48536
-------------	-------

Installation manual	MVS21736
---------------------	----------

OFF position locking / 1 part

E46735

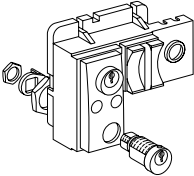

By Profalux keylocks

Profalux	1 lock with 1 key + adaptation kit	64928
	2 locks 1 keys + adaptation kit	64929
	Profalux 1 lock+ 1 key (without adaptation kit)	42888
	Profalux 2 locks + 1 key (without adaptation kit)	42878
	Adaptation kit (without key locks)	64925

By Ronis keylocks

Ronis	1 lock with 1 key + adaptation kit	64931
	2 locks 1 keys + adaptation kit	64932
	Ronis 1 lock+ 1 key (without adaptation kit)	41940
	Ronis 2 locks + 1 key (without adaptation kit)	41950
	Adaptation kit (without key locks)	64925

Installation manual	MVS21736
---------------------	----------

Mechanical operation counter / 1 part

DB125617



Operation counter CDM	48535
-----------------------	-------

Installation manual	MVS21736
---------------------	----------

Escutcheon and accessories / 1 part

CDB50061

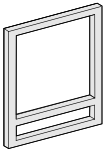

Escutcheon

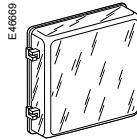

Cover

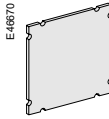

Blanking plate

	Fixed	Draw-out
Escutcheon	48601	48603
Transparent cover (IP 54)	-	48604
Escutcheon blanking plate	48605	48605

Installation manual	MVS21736
---------------------	----------

Mechanical interlocking for source changeover

Interlocking of 2 devices using cables ⁽¹⁾

CDB500053

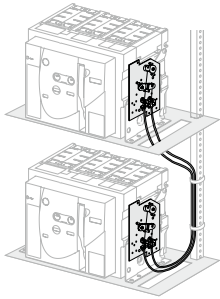

Choose 2 adaptation sets (1 for each device + 1 set of cables)

1 adaptation fixture for EasyPact MVS fixed devices	47926
1 adaptation fixture for EasyPact MVS draw-out devices	47926
1 set of 2 cables	33209

(1) Can be used with any combination of EasyPact MVS, fixed or draw-out devices.

Installation manual	MVS21738
---------------------	----------

Interlocking of 3 devices using cables

CDB500060

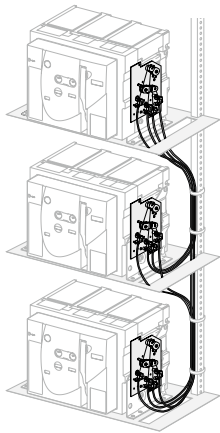

Choose 3 adaptation (including 3 adaptation fixtures + cables)

3 sources, only 1 device closed, fixed or draw-out devices	48610
2 sources + 1 coupling, fixed or draw-out devices	48609
2 normal + 1 replacement source, fixed or draw-out devices	48608
Installation manual	MVS21738

Indication contacts

ON/OFF indication contacts (OF) / 12 parts

E46889

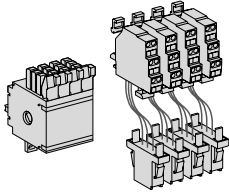

1 additional block of 4 contacts		47887
Wiring	For fixed circuit breaker	47074
	For draw-out circuit breaker	47849

Installation manual		MVS21736
---------------------	--	----------

"Ready to close" contact (1 max.) / 1 part

E46438

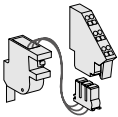

1 changeover contact (5 A - 240 V)		47080
Wiring	For fixed circuit breaker	47074
	For draw-out circuit breaker	47849

Installation manual		MVS21736
---------------------	--	----------

"Connected, disconnected, test position" indication contact (carriage switches) / 1 part

E46861

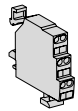

Changeover contacts	6 A - 240 V	33170
---------------------	-------------	-------

Installation manual		MVS21736
---------------------	--	----------

Auxiliary terminals for chassis alone

3 wire terminal (1 part)		47849
6 wire terminal (1 part)		47850
Jumpers (10 parts)		47900

Instructions

EasyPact MVS User Manual (English)	MVS21734
Fixed & draw-out circuit breaker	MVS21735
Circuit breaker accessories	MVS21736
Chassis accessories	MVS21737
Interlocking of EasyPact MVS devices	MVS21738
MVS Communication user manual	MVS21835

Order ref no:

Date:

Product ref no:

OA No.
(to be filled by Order booking team)

EasyPact MVS

Circuit breaker and Switch-disconnectors Customer Order form

To indicate your choices, check the applicable square boxes

And enter the appropriate information in the rectangles

Circuit breaker or switch-disconnector Quantity

Rating	A	<input type="checkbox"/>
Circuit breaker	C/N/ H	<input type="checkbox"/>
Switch Disconnecter	CA/NA/HA	<input type="checkbox"/>
Number of poles	3 or 4	<input type="checkbox"/>
Optional Neutral on Right hand side	YES	<input type="checkbox"/>
Type of equipment	Fixed	<input type="checkbox"/>
	Draw out with chassis	<input type="checkbox"/>
	Draw out without chassis (moving part only)	<input type="checkbox"/>
	Chassis alone	<input type="checkbox"/>
Operating Mechanism	Manual Operated	<input type="checkbox"/>
	Electrical Operated	<input type="checkbox"/>
MCH - Gear motor	V	<input type="checkbox"/>
XF - Closing coil	V	<input type="checkbox"/>
MX - Shunt/Opening voltage release	V	<input type="checkbox"/>

ET Trip System

0 - Without display	2I	<input type="checkbox"/>	5S	<input type="checkbox"/>	6G	<input type="checkbox"/>
A - Current Metering	2I	<input type="checkbox"/>	5S	<input type="checkbox"/>	6G	<input type="checkbox"/>
V - Energy Metering	2I	<input type="checkbox"/>	5S	<input type="checkbox"/>	6G	<input type="checkbox"/>
LR - Long-time rating plug	Standard	0.4 to 1 Ir				

Communication

Eco Com Module(only ETV Trip System)

Device(BCM ULP) Cradle management with

Modbus Interface(IFM) I/O application module (Chassis)

Breaker ULP Cord L=0.35m L=1.3m L=3m

Easy Communication Module
EasyCom Communication Module

Programmable contacts
2 M2C contacts(only with ETV Trip System)

Connection

Horizontal	Top	<input type="checkbox"/>	Bottom	<input checked="" type="checkbox"/>
Vertical	Top	<input checked="" type="checkbox"/>	Bottom	<input type="checkbox"/>

Trip System functions:
 2I : Basic protection (long time + inst.)
 5S : Selective protection (long time + short time + inst.)
 6G : Selective + earth-fault protection
 (long time + short time + inst. + earth-fault)

Notes:
 Customer can provide only the reference no. of the product for the listed references. Kindly refer to product catalogue for list of references.
 Customer to fill this order form for non-listed references.
 All breakers will be provided with 1 OF (4 c/o contacts), 1 SDE (trip contact), Escutcheon (Panel sealing frame) as standard.
 All draw-out breakers/switches will be supplied with Chassis & safety shutter.
 For Electrical operated breakers/ switches, indicate the voltage ratings of MCH, XF & MX
 Refer to product catalogue for available voltage ratings of MCH/XF/MX/MN & AD Module
 The orientation of customer connecting terminals can be changed at site from Horizontal to vertical or vice-versa.

Indication contacts

OF - ON/OFF indication contacts

Standard	1 block of 4 OF	10 A-240/380V AC	<input type="checkbox"/>
Additional(not incl MVS C/CA)	1 block of 4 OF	6 A-240/380V AC	<input type="checkbox"/>

SDE - "fault-trip" indication contact

Standard	1 SDE	5A-240/380V AC	<input type="checkbox"/>
-----------------	-------	----------------	--------------------------

Optional

Carriage switches 8 A-240/380V AC

CE - "Connected" position	Max. 3	qty	<input type="text"/>
CT - "Test" position	Max. 3	qty	<input type="text"/>
CD - "Disconnected" position	Max. 3	qty	<input type="text"/>

Remote tripping

MN - Under voltage release		V	<input type="checkbox"/>
R - Delay unit (fixed time delay)	0.25s		<input type="checkbox"/>
Rr - Adjustable delay unit	0.5s.....3s		<input type="checkbox"/>

AD - External power-supply module **V**

TCE - MVS C- External sensor (NCT) for neutral of 3 Phase-4 Wire systems 400/1600A

TCE - MVS N/H- External sensor (NCT) for neutral of 3 Phase-4 Wire systems 400/2000A

TCE - MVS N/H- External sensor (NCT) for neutral of 3 Phase-4 Wire systems 1000/4000A

PF - "Ready to close" contact 5A-240/380V AC

Locks

VBP - ON/OFF pushbutton locking (by transparent cover using padlock)

VSPO - Device locking in OFF position by key lock (Only one key lock per ACB possible)

Key lock kit (w/o key lock)	Profalux	<input type="checkbox"/>	Ronis	<input type="checkbox"/>
1 key lock	Profalux	<input type="checkbox"/>	Ronis	<input type="checkbox"/>
2 identical key locks, 1 key(non include MVS C/CA)	Profalux	<input type="checkbox"/>	Ronis	<input type="checkbox"/>

Chassis locking in "Disconnected" position:

VSPD - by key locks	Key lock kit (w/o key lock)	Profalux	<input type="checkbox"/>	Ronis	<input type="checkbox"/>
	1 key lock	Profalux	<input type="checkbox"/>	Ronis	<input type="checkbox"/>
	2 identical key locks, 1 key	Profalux	<input type="checkbox"/>	Ronis	<input type="checkbox"/>

Door Interlock - VPEC

On left-hand side of chassis (LH)

On right-hand side of chassis (RH)

Mechanical Interlocking of ACBs with Cable

1 Normal source & 1 replacement source (2 devices)	<input type="checkbox"/>
2 normal + 1 replacement source, fixed or draw-out devices	<input type="checkbox"/>
2 sources with coupler on busbars (3 devices)	<input type="checkbox"/>
3 sources, only 1 device closed, fixed or draw-out devices	<input type="checkbox"/>

Accessories

VO - Safety shutters on chassis	Standard	<input type="checkbox"/>
CDP - Escutcheon	Standard	<input type="checkbox"/>
Safety Shutter locking blocks		<input type="checkbox"/>
CP - Transparent cover for escutcheon		<input type="checkbox"/>
OP - Blanking plate for escutcheon		<input type="checkbox"/>
CDM - Mechanical operation counter for MVS(not incl MVS C/CA)		<input type="checkbox"/>
CB - Auxiliary terminal shield fitted on chassis		<input type="checkbox"/>
EIP - Interphase barriers		<input type="checkbox"/>
HHTK - Hand held test kit		<input type="checkbox"/>

Life Is On

Schneider
Electric

Schneider Electric Industries SAS

35, rue Joseph Monier
CS 30323
92506 Rueil Malmaison Cedex
France

RCS Nanterre 954 503 439
Capital social 928 298 512 €
www.se.com

Jan-2021

© 2019 - Schneider Electric. All Rights Reserved.
All trademarks are owned by Schneider Electric Industries SAS or its affiliated companies.
Document reference LVED211021EN

This document has been
printed on recycled paper

